

SPECIFICATIONS

CUSTOMER : _____

SAMPLE CODE : GFG128064A-FPFE-01

DRAWING NO. : _____

DATE : 2009.03.02

CERTIFICATION : ROHS

Customer Sign	Sales Sign	Approved By	Prepared By

Revision Record

Data(y/m/d)	Ver.	Description	Note	page
2009.03.02	00	New		18

CONTENTS

1.	SCOPE	-----	4
2.	PRODUCT SPECIFICATIONS	-----	4
2.1	General	-----	4
2.2	Mechanical Characteristics	-----	4
2.3	Absolute Maximum Ratings	-----	5
2.4	Electrical Characteristics	-----	5
2.5	Optical Characteristics Absolute maximum ratings	-----	5
2.6	Optical Characteristics	-----	6
2.7	LED Back-light Characteristics	-----	7
3.	RELIABILITY	-----	8
4.	OPERATING INSTRUCTIONS	-----	9

4.1	Input signal Function	-----	9
4.2	Voltage Generator Circuit	-----	10
4.3	Timing Diagram	-----	13
5.	NOTES	-----	16
6.	OPERATION PRECAUTIONS	-----	16
7.	LCM DIMENSIONS	-----	17

1. SCOPE

This specification covers the engineering requirements for the GFG128064A-FPFE-01 liquid crystal module.

2. PRODUCT SPECIFICATIONS

2.1 General

- 128 \times 64 dot matrix LCD
- FSTN , Positive mode LCD panel
- Transflective , Wide temperature type
- 6 o'clock
- Back light: Edge LED (WHITE)
- Multiplexing driving : 1/65duty, 1/9bias
- Conteroller IC UC1601

2.2 Mechanical Characteristics

Item	Characteristic
Dot configuration	128 ◇64
Dot dimensions(mm)	0.334 ◇0.403
Dot spacing (mm)	0.364 ◇0.433
Module dimensions (Horizontal ◇ Vertical ◇Thickness, mm)	56.6 ◇44.2 ◇7.65 max.
Viewing area (Horizontal ◇ Vertical, mm)	50.6 ◇31
Active area (Horizontal ◇Vertical, mm)	46.562 ◇27.682

2.3 Absolute Maximum Ratings (Without LED

back-light)

Characteristic	Symbol	Unit	Value
Operating Voltage (logic)	V_{DD}	V	-0.3 to +4.0
Input Voltage	V_{IN}	V	-0.3 to $V_{DD}+0.3$

Note 1: Referenced to $V_{SS}=0V$

2.4 Electrical Characteristics (Without LED back-light)

Symbol	Parameter	Conditions	Min.	Typ.	Max.	Unit
V_{DD}	Supply for digital circuit		2.4		3.3	V
$V_{DD2/3}$	Supply for bias & pump		2.4		3.3	V
V_{LCD}	Charge pump output	$V_{DD2/3} \geq 2.4V, 25^{\circ}C$			11.5	V
V_D	LCD data voltage	$V_{DD2/3} \geq 2.4V, 25^{\circ}C$	0.80		1.32	V
V_{IL}	Input logic LOW				$0.2V_{DD}$	V
V_{IH}	Input logic HIGH		$0.8V_{DD}$			V
V_{OL}	Output logic LOW				$0.2V_{DD}$	V
V_{OH}	Output logic HIGH		$0.8V_{DD}$			V
I_{IL}	Input leakage current				1.5	μA
$R_{0(SEG)}$	SEG output impedance	$V_{LCD} = 11V$		2	3	$k\Omega$
$R_{0(COM)}$	COM output impedance	$V_{LCD} = 11V$		2	3	$k\Omega$
F_{FR}	Average Frame Rate	LC[3] = 0b	66	76	--	Hz

2.5 Optical Characteristics Absolute maximum ratings

Item	Symbol	Rating	Unit
------	--------	--------	------

Operating temperature range	Top	-20~70	°C
Storage temperature range	Tst	-30~80	°C

2.6 Optical Characteristics

1/65 duty, 1/9bias, Vop=10.2V, Ta=25°C

Item	Symbol	Conditions	Min.	Typ.	Max	Reference
Driving voltage	Vop=VDD-VO			10.2		
Viewing angle	-	$C \geq 2.0, \theta = 0^\circ$	30	--	--	Notes 1 & 2
Contrast	C	$\theta = 5^\circ, \theta = 0^\circ$	3.0	--	--	Note 3
Response time(rise)	ton	$\theta = 5^\circ, \theta = 0^\circ$	--	--	198ms	Note 4
Response time(fall)	toff	$\theta = 5^\circ, \theta = 0^\circ$	--	--	176ms	Note 4

Note 1: Definition of angles θ and θ'

Note 2: Definition of viewing angles θ_1 and θ_2

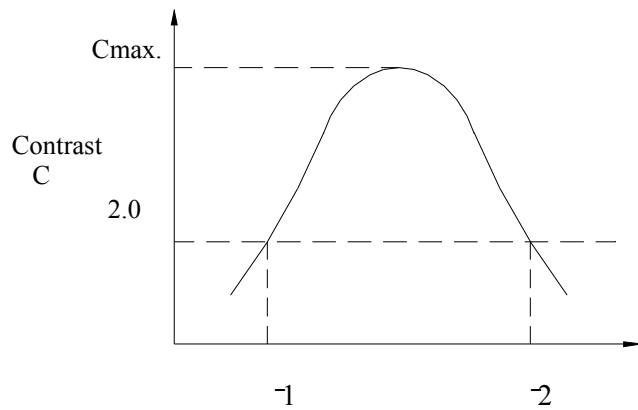
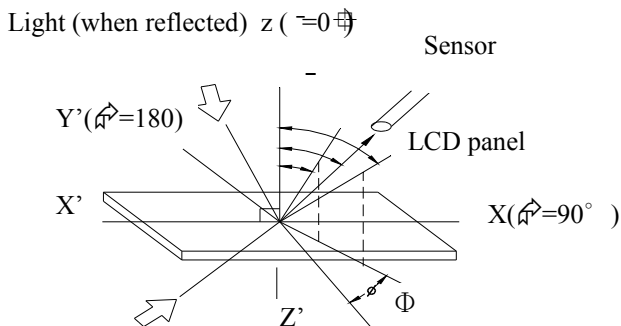

Light (when transmitted) $\theta' = 0^\circ$
 $\theta = 90^\circ$

viewing angle θ (Φ fixed)

Note : Optimum viewing angle with the naked eye and viewing angle θ at Cmax. Above are not always the same

Note 3: Definition of contrast C

Note 4: Definition of response time

Brightness (reflection) of unselected dot (B2)

$$C = \frac{\text{Brightness (reflection) of selected dot (B1)}}{\text{Brightness (reflection) of unselected dot (B2)}}$$

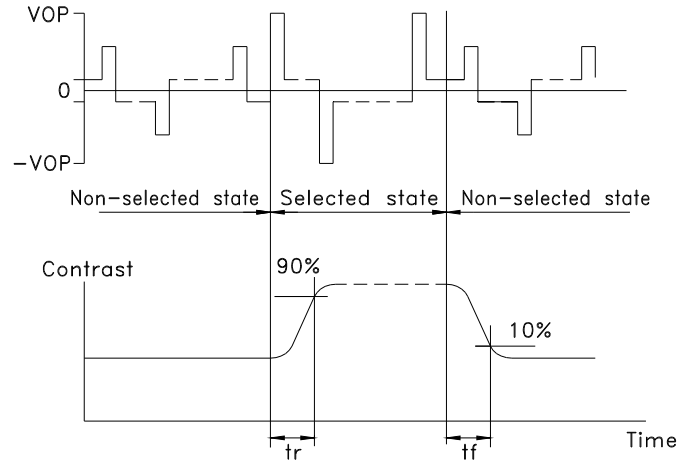
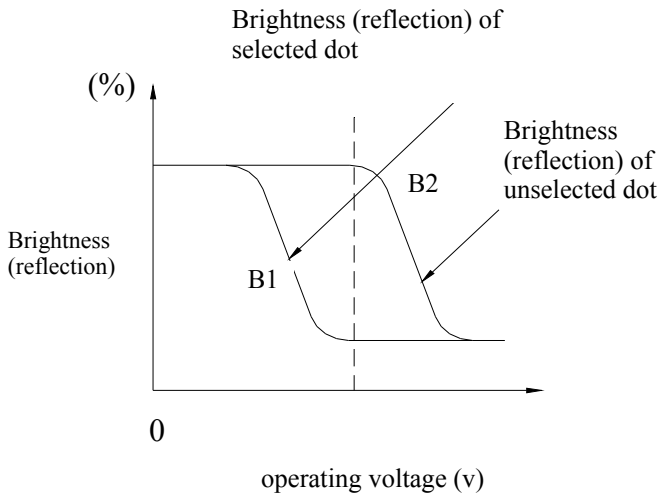

Note: Measured with a transmissive LCD panel which is displayed 1 cm²

V_{OPR} : Operating voltage f_{FRM} : Frame frequency
 t_{ON} : Response time (rise) t_{OFF} : Response time (fall)

2.7 LED Back-light Characteristics

2.7.1 Electrical / optical specifications

$T_a = 25^{\circ}C$

Item	Symbol	Condition	Min.	Typ.	Max.	Unit
Forward voltage	V_f	$I_f=40mA$, WHITE	2.9	3.2	3.6	V
LED *Luminous Intensity	I_v	$I_f=40mA$, WHITE	--	120	--	Cd/m ²
Chromaticity Coordinate	x	$I_f=40mA$, WHITE	0.26	0.31	0.36	
	y		0.25	0.32	0.37	
Reverse Current	I_R	$V_R=5V$, WHITE	--	--	0.1	mA

Note: *
Measured at
the bare
LED back-
light unit.

2.7.2 LED

Maximum Operating Range

Item	Symbol	WHITE	Unit
Power Dissipation	P_{AD}	144	mW
Forward Current	I_F	40	mA
Reverse Voltage	V_R	5	V

3. RELIABILITY

3.1 Reliability

Test item	Test condition	Evaluation and assessment
Operation at high temperature and humidity	40 °C \pm 2 °C 90%RH for 500hours	No abnormalities in functions* and appearance**
Operation at high temperature	60 °C \pm 2 °C for 500 hours	No abnormalities in functions* and appearance**
Heat shock	-20 ϕ ~ +60 °C Left for 1 hour at each temperature, transition time 5 min, repeated 10times	No abnormalities in functions* and appearance**
Low temperature	-20 \pm 2 °C for 500 hours	No abnormalities in functions* and appearance**
Vibration	Sweep for 1 min at 10 Hz, 55Hz, 10Hz, amplitude 1.5mm 2 hrs each in the X,Y and Z directions	No abnormalities in functions* and appearance**
Drop shock	Dropped onto a board from a height of 10cm	No abnormalities in functions* and appearance**

* Dissipation current, contrast and display functions

** Polarizing filter deterioration, other appearance defects

3.2 Liquid crystal panel service life

100,000 hours minimum at 25 °C \pm 10 °C

3.3 definition of panel service life

- Contrast becomes 30% of initial value
- Current consumption becomes three times higher than initial value
- Remarkable alignment deterioration occurs in LCD cell layer
- Unusual operation occurs in display functions

4. OPERATING INSTRUCTIONS

4.1 Input signal Function

Pin No	Symbol	I/O	Function																											
1~4	NC	-	No Connection.																											
5	V _{LCD}	PWR	Main LCD power supply.																											
6	V _{B0+}	PWR	LCD Bias Voltages. These are the voltage sources to provide SEG driving currents. These voltages are generated internally. Connect capacitors of C _{BX} value between V _{BX+} and V _{BX-} .																											
7	V _{B0-}	PWR																												
8	V _{B1-}	PWR																												
9	V _{B1+}	PWR																												
10	V _{SS}	PWR	Power Ground.																											
11	V _{DD}	PWR	Power supply terminal V _{CC} .																											
12	BM1	I	Bus mode: "HL": 8080 "HH": 6800 BM[1:0] "LH": S9 "LL": S8																											
13	BM0	I																												
14	DB7	I/O	Bi-directional bus for both serial and parallel host interfaces. In serial modes, connect DB0 to SCK, DB3 to SDA.																											
15	DB6	I/O																												
16	DB5	I/O																												
17	DB4	I/O																												
18	DB3/SDA	I/O																												
19	DB2	I/O																												
20	DB1	I/O																												
21	DB0/SCK	I/O																												
			<table border="1"> <thead> <tr> <th></th> <th>BM=1x (Parallel)</th> <th>BM=0x (Serial)</th> </tr> </thead> <tbody> <tr> <td>D0</td> <td>D0</td> <td>SCK</td> </tr> <tr> <td>D1</td> <td>D1</td> <td></td> </tr> <tr> <td>D2</td> <td>D2</td> <td></td> </tr> <tr> <td>D3</td> <td>D3</td> <td>SDA</td> </tr> <tr> <td>D4</td> <td>D4</td> <td></td> </tr> <tr> <td>D5</td> <td>D5</td> <td></td> </tr> <tr> <td>D6</td> <td>D6</td> <td>-</td> </tr> <tr> <td>D7</td> <td>D7</td> <td>-</td> </tr> </tbody> </table>		BM=1x (Parallel)	BM=0x (Serial)	D0	D0	SCK	D1	D1		D2	D2		D3	D3	SDA	D4	D4		D5	D5		D6	D6	-	D7	D7	-
	BM=1x (Parallel)	BM=0x (Serial)																												
D0	D0	SCK																												
D1	D1																													
D2	D2																													
D3	D3	SDA																												
D4	D4																													
D5	D5																													
D6	D6	-																												
D7	D7	-																												
22	WR1	I	WR [1:0] controls the read/write operation of the host interface. See Host Interface section for details. The meaning of WR [1:0] depends on whether the interface is in the 6800 mode, or the 8080 mode. In serial modes, these two pins are not used and can be connected to V _{ss} .																											
23	WR0	I																												
24	CD	I	Select the incoming command if it is a control instruction or for display data. CD pin is not used in S9 mode, connect it to V _{dd} or V _{ss} . "L": control instruction "H": display data																											
25	RST	I	When RST="L", all control registers are re-initialized by their default states.																											

26	/CS0	I	Chip Select or Chip Address. In parallel mode and S8 mode, chip is selected when /CS0="L". When the chip is not selected, DB[7:0] will be high impedance.
27~30	NC	-	No Connection.

Bus Type		8080	6800	SPI (S8)	SPI (S9)	
Control & Data Pins	BM[1:0]	10b	11b	00b	01b	
	CS[1:0]	Chip Select				
	CD	Control/Data			-	
	WR0	\overline{WR}	R/ \overline{W}	-		
	WR1	\overline{RD}	EN	-		
	Access	Read/Write			Write Only	
	D[7:0]	8-bit bus (Tri-state)			D0=SCK, D3=SDA	

* Connect unused control pins and data bus pins to V_{DD} or V_{SS}

4.2 Voltage Generator Circuit

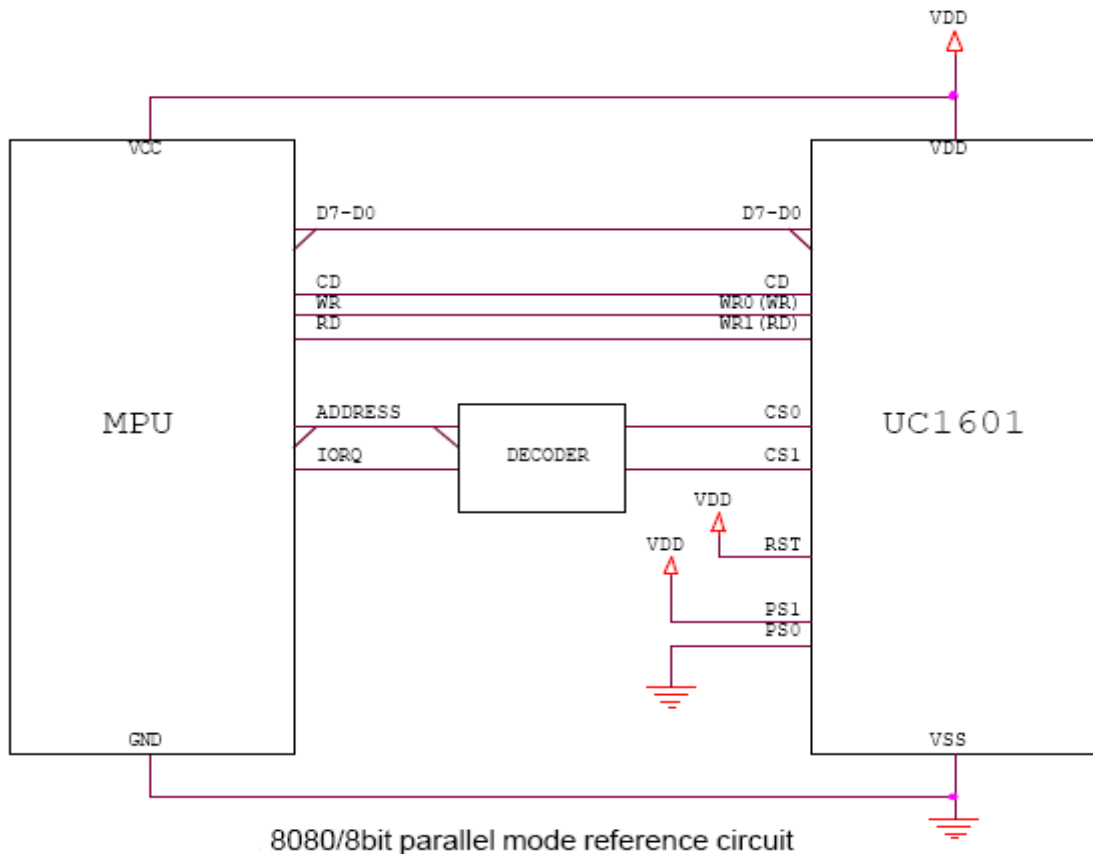

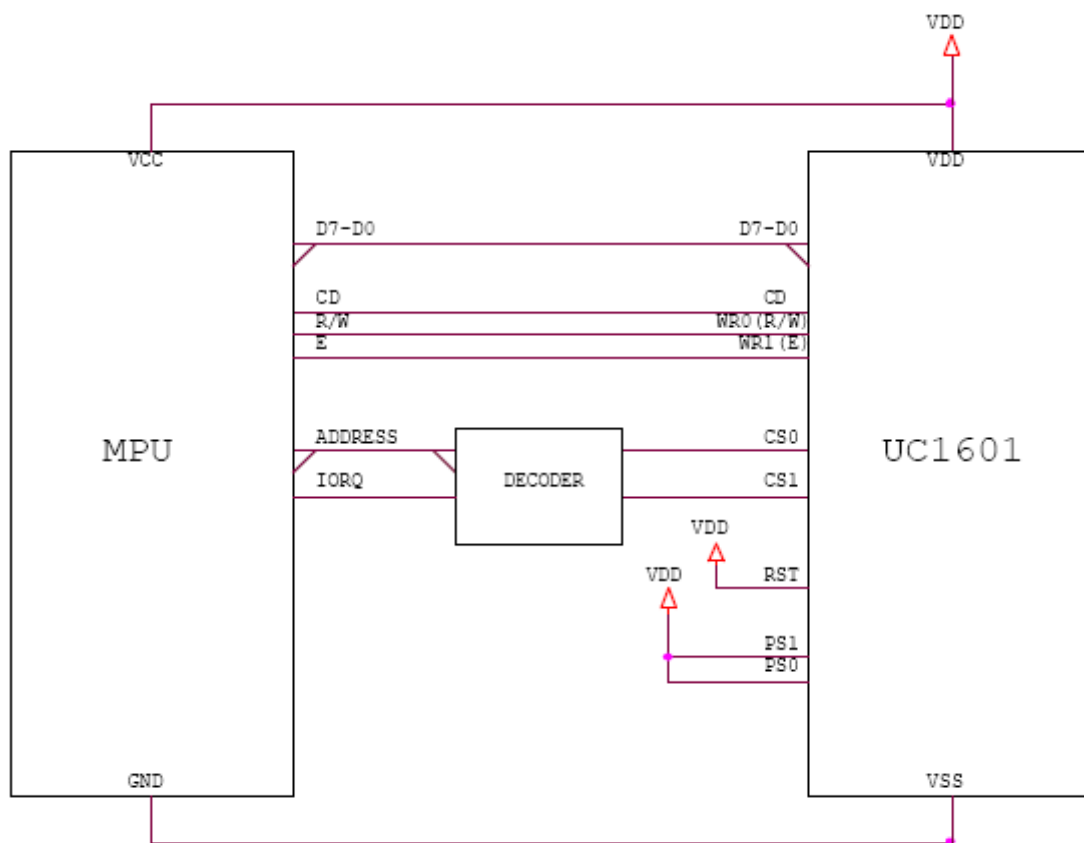

6800/8bit parallel mode reference circuit

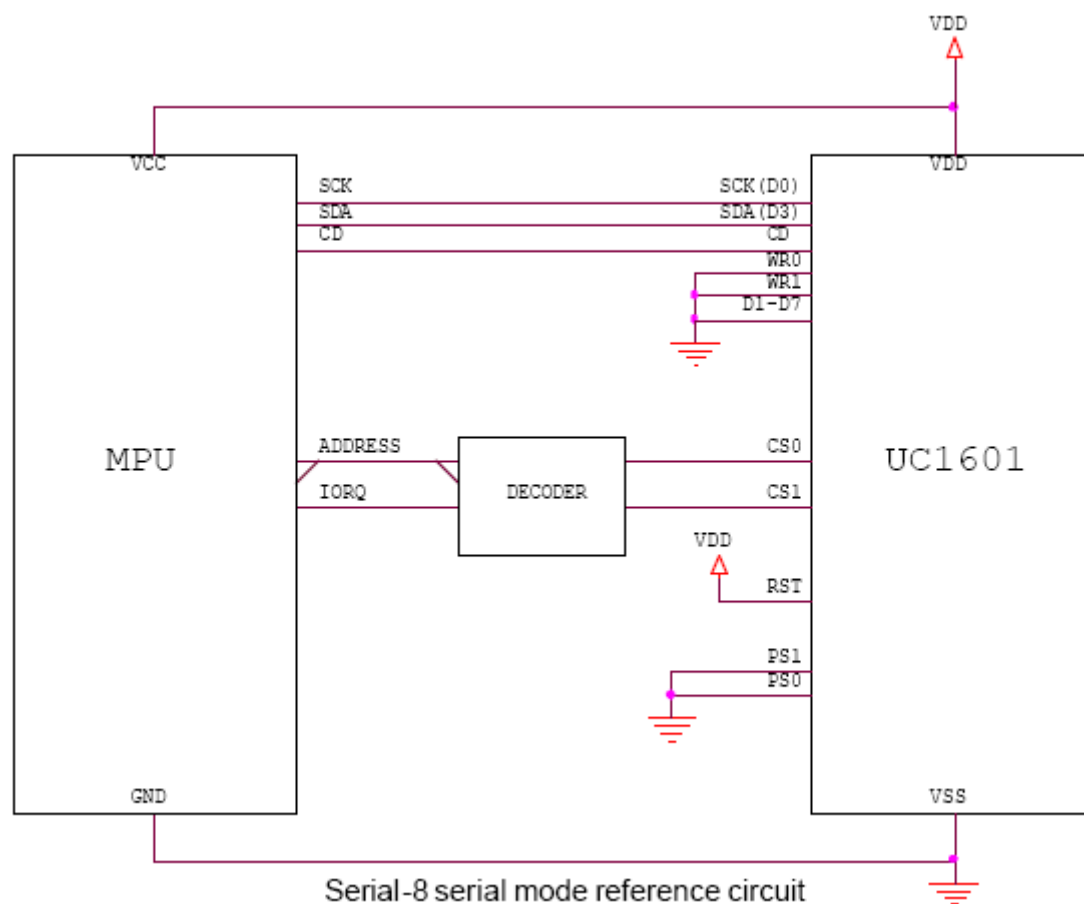

Serial-8 serial mode reference circuit

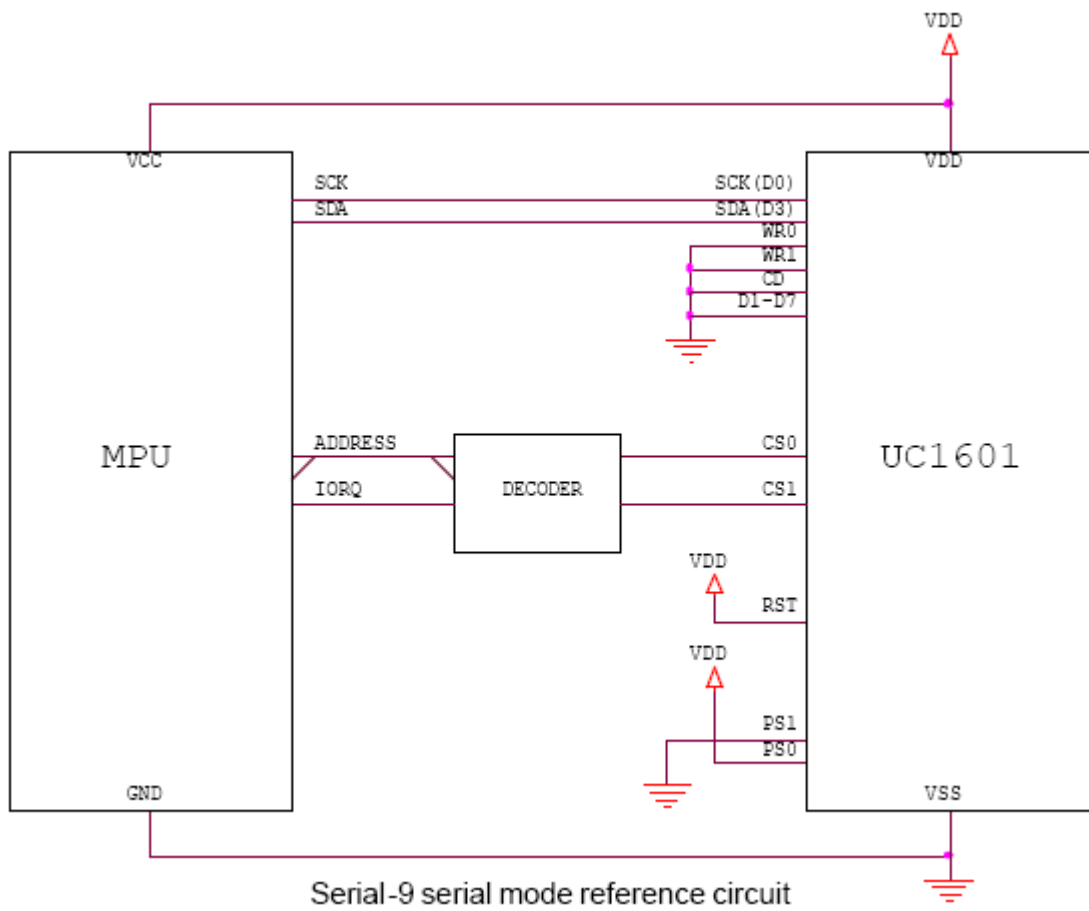

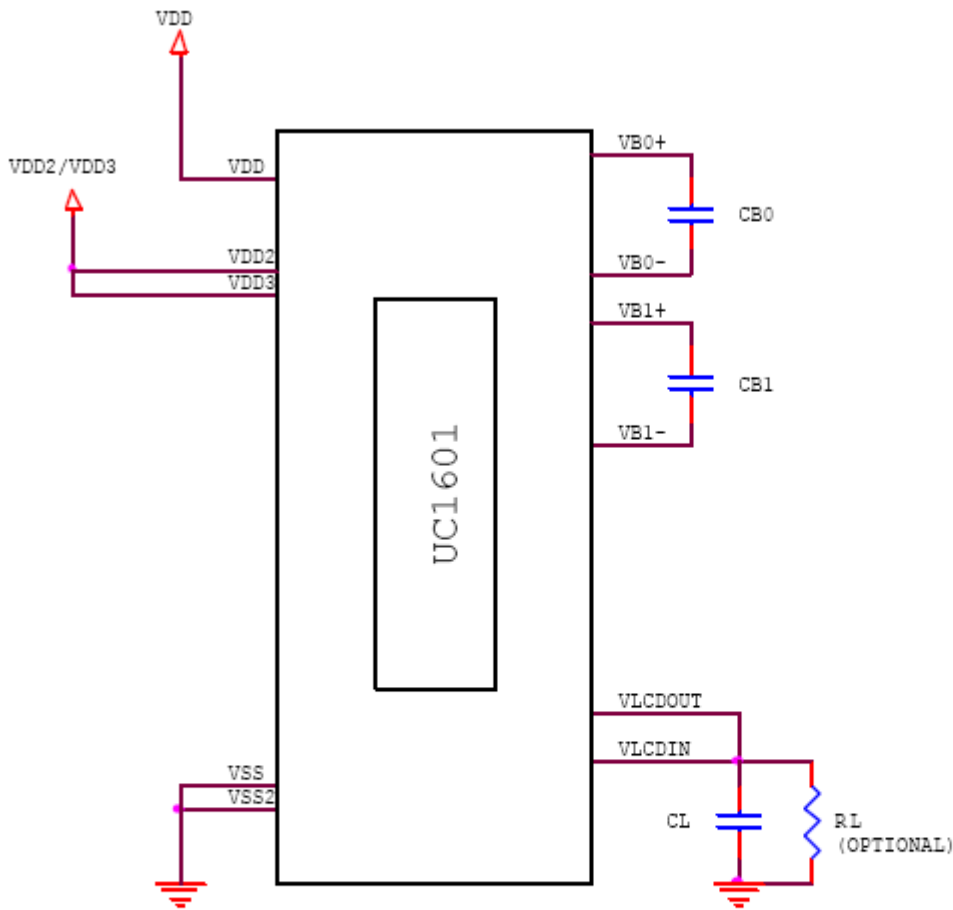

Note

- Recommended component values:
 C_B : 100x~200x LCD load capacitance or 1.0uF (2V), whichever is higher.
 C_L : 10nF ~ 30nF (25V) is appropriate for most applications.
 R_L : 10M Ω . Acts as a draining circuit when the power is abnormally shut down.

4.3 Timing Diagram

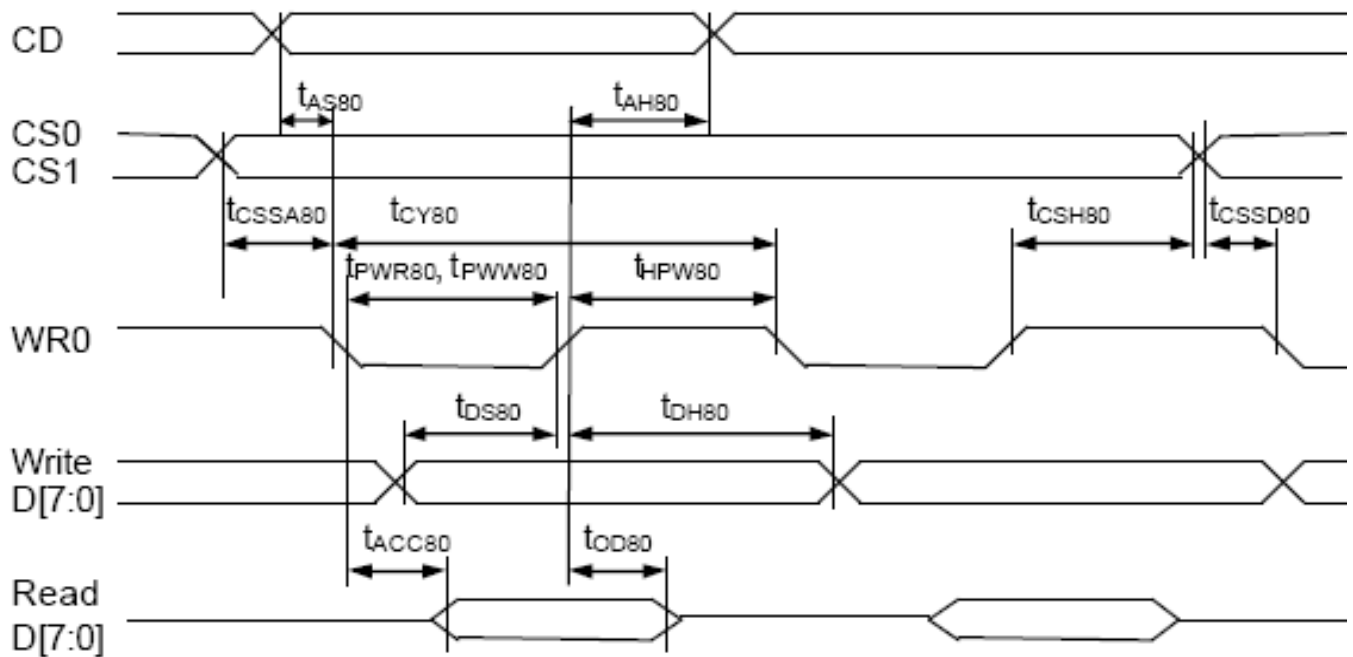

Parallel Bus Timing Characteristics (for 8080 MCU)

($2.5V \leq V_{DD} < 3.3V$, $T_a = -30$ to $+85^\circ C$)

Symbol	Signal	Description	Condition	Min.	Max.	Units
t_{AS80}	CD	Address setup time		0	-	nS
t_{AH80}		Address hold time		40	-	nS
t_{CY80}		System cycle time		135	-	nS
t_{PWR80}	WR1	Pulse width (read)		65	-	nS
t_{PWW80}	WR0	Pulse width (write)		65	-	nS
t_{HPW80}	WR0, WR1	High pulse width		65	-	nS
t_{DS80}	D0~D7	Data setup time		30	-	nS
t_{DH80}		Data hold time		20	-	nS
t_{ACC80}		Read access time	$C_L = 100pF$	-	50	nS
t_{OD80}		Output disable time		10	50	nS
t_{CSSA80}	CS1/CS0	Chip select setup time		10		nS
t_{CSSD80}				10		nS
t_{CSH80}				20		nS

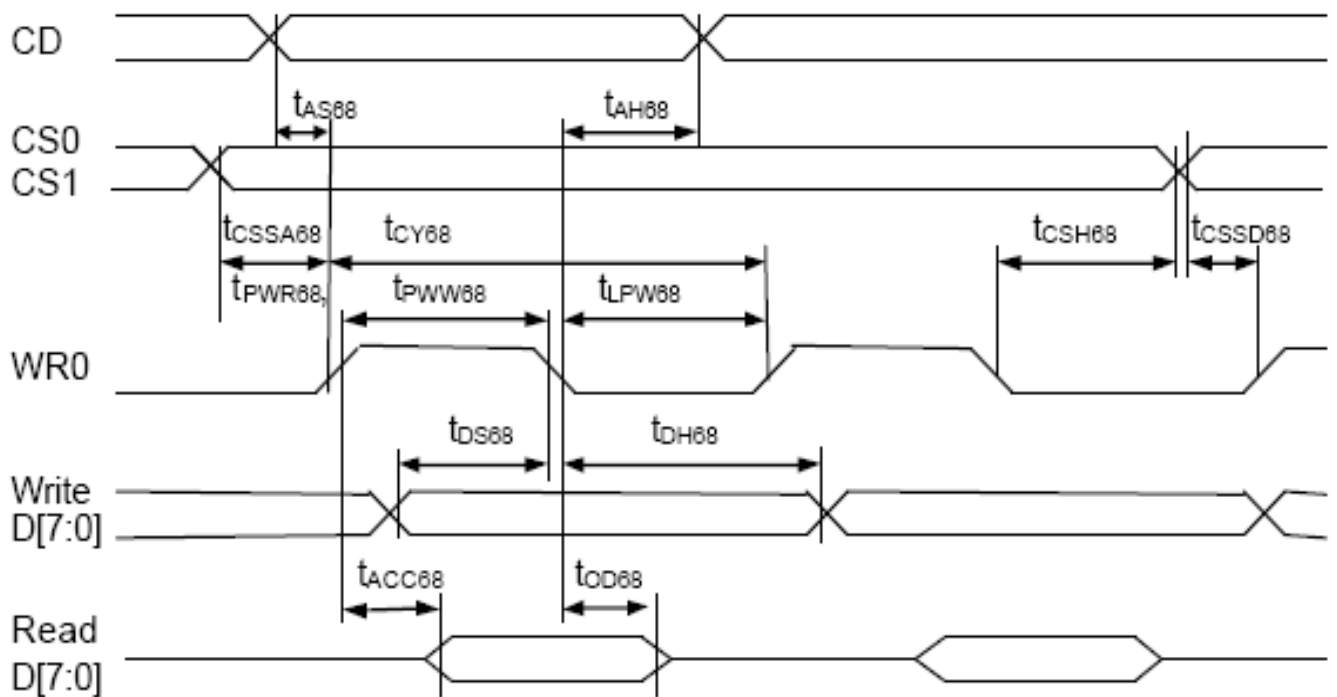

Parallel Bus Timing Characteristics (for 6800 MCU)

($2.5V \leq V_{DD} < 3.3V$, $T_a = -30$ to $+85^\circ C$)

Symbol	Signal	Description	Condition	Min.	Max.	Units
t_{AS88}	CD	Address setup time		0	-	nS
t_{AH88}		Address hold time		40	-	nS
t_{CY88}		System cycle time		135	-	nS
t_{PWR88}	WR1	Pulse width (read)		65	-	nS
t_{PWW88}		Pulse width (write)		65	-	nS
t_{LPW88}		Low pulse width		65	-	nS
t_{DS88}	D0~D7	Data setup time		30	-	nS
t_{DH88}		Data hold time		15	-	nS
t_{ACC88}		Read access time	$C_L = 100pF$	-	50	nS
t_{OD88}		Output disable time		10	50	nS
T_{CSSA88}	CS1/CS0	Chip select setup time		10		nS
T_{CSSD88}				10		nS
T_{CSH88}				20		nS

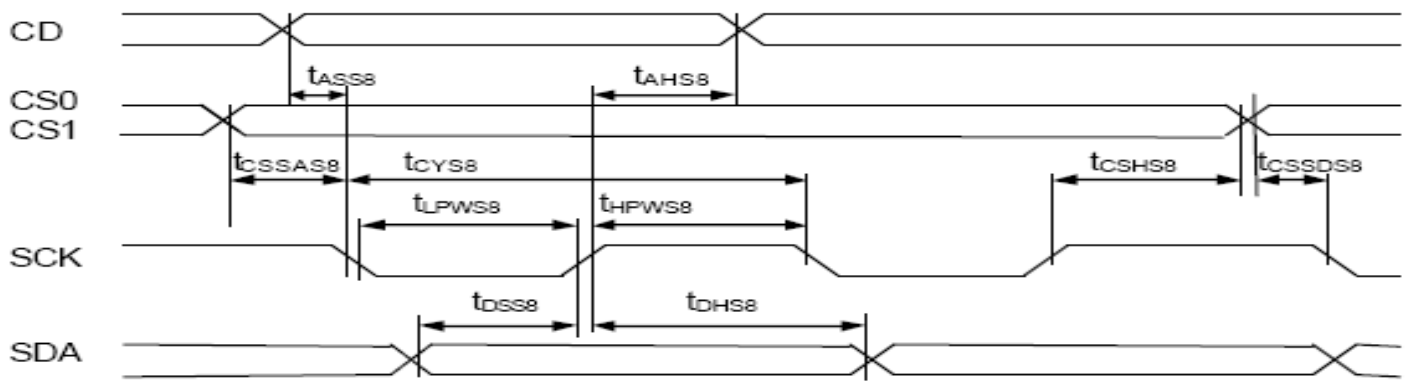

Serial Bus Timing Characteristics (for S8)

($2.5V \leq V_{DD} < 3.3V$, $T_a = -30$ to $+85^\circ C$)

Symbol	Signal	Description	Condition	Min.	Max.	Units
t_{ASS8}	CD	Address setup time		0	–	nS
t_{AHS8}		Address hold time		40	–	nS
t_{CYS8}	SCK	System cycle time		135	–	nS
t_{LPWS8}		Low pulse width		65	–	nS
t_{HPWS8}		High pulse width		65	–	nS
t_{DSS8}	SDA	Data setup time		30	–	nS
t_{DHS8}		Data hold time		15	–	nS
t_{CSSAS8} t_{CSSDS8} t_{CSS8}	CS1/CS0	Chip select setup time		10 10 20		nS

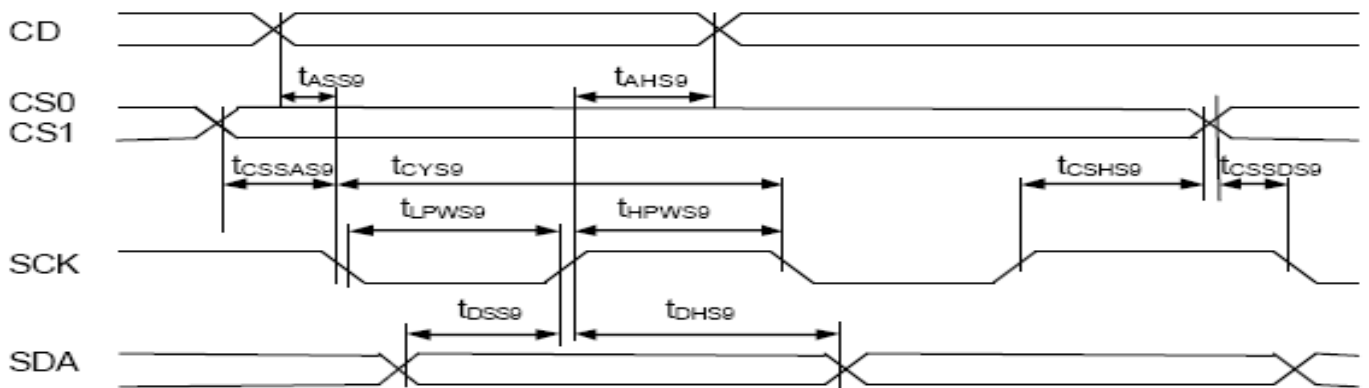

Serial Bus Timing Characteristics (for S9)

($2.5V \leq V_{DD} < 3.3V$, $T_a = -30$ to $+85^\circ C$)

Symbol	Signal	Description	Condition	Min.	Max.	Units
t_{ASS9}	CD	Address setup time		0	–	nS
t_{AHS9}		Address hold time		40	–	nS
t_{CYS9}	SCK	System cycle time		135	–	nS
t_{LPWS9}		Low pulse width		65	–	nS
t_{HPWS9}		High pulse width		65	–	nS
t_{DSS9}	SDA	Data setup time		30	–	nS
t_{DHS9}		Data hold time		15	–	nS
t_{CSSAS9} t_{CSSDS9} t_{CSS9}	CS1/CS0	Chip select setup time		10 10 20		nS

5. NOTES

Safety

- If the LCD panel breaks, be careful not to get the liquid crystal in your mouth. If the liquid crystal touches your skin or clothes, wash it off immediately using soap and plenty of water.

Handling

- Avoid static electricity as this can damage the CMOS LSI.
- The LCD panel is plate glass; do not hit or crush it.
- Do not remove the panel or frame from the module.
- The polarizing plate of the display is very fragile; handle it very carefully

Mounting and Design

- Mount the module by using the specified mounting part and holes.
- To protect the module from external pressure, leave a small gap by placing transparent plates (e.g. acrylic or glass) on the display surface, frame, and polarizing plate
- Design the system so that no input signal is given unless the power-supply voltage is applied.
- Keep the module dry. Avoid condensation, otherwise the transparent electrodes may break.

Storage

- Store the module in a dark place where the temperature is $25^{\circ}\text{C} \pm 10^{\circ}\text{C}$ and the humidity below 65% RH.
- Do not store the module near organic solvents or corrosive gases.
- Do not crush, shake, or jolt the module (including accessories).

Cleaning

- Do not wipe the polarizing plate with a dry cloth, as it may scratch the surface.
- Wipe the module gently with soft cloth soaked with a petroleum benzine.
- Do not use ketonic solvents (ketone and acetone) or aromatic solvents (toluene and xylene), as they may damage the polarizing plate.

6. OPERATION PRECAUTIONS

Any changes that need to be made in this specification or any problems arising from it will be dealt with quickly by discussion between both companies.

7. LCM Dimension

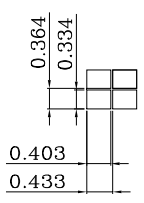
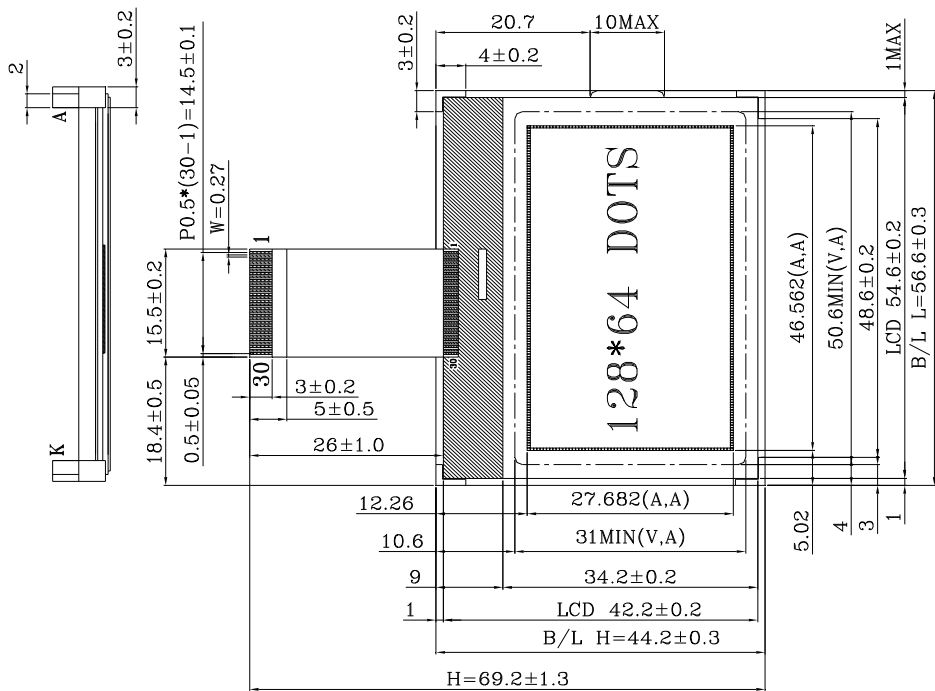

PIN FUNCTION

PIN	NAME	PIN	NAME
1	NC	16	D5
2	NC	17	D4
3	NC	18	D3/SDA
4	NC	19	D2
5	VLCD	20	D1
6	VBO+	21	po/sck
7	VBO-	22	WR1
8	VBI-	23	WR0
9	VBI+	24	CD
10	VSS	25	RST
11	VDD	26	/CSO
12	BMI	27	NC
13	BMO	28	NC
14	D7	29	NC
15	D6	30	NC

- NOTES:**
- 1.DRIVE METHOD: 1/65DUTY, 1/9BIAS,VDD:3.0V, VOP:10.2V.
 - 2.VIEWING ANGLE: 6 0'CLOCK.
 - 3.DISPLAY TYPE: FSTN, TRANSPARENTIVE(高半透)/POSITIVE.
 - 4.OPERATING TEMP: -20°C TO 70°C.
 - 5.STORAGE TEMP: -30°C TO 80°C.
 - 6.IC:UC1601.
 - 7.BACKLIGHT:WHITE.
 - 8.CONNECTION:COG+FPC.Small panel is on top layer
 - 9.LCD印刷客户料號: LCM28064_023
 - 10.NOT DIMENSION TOLERANCES IS ±0.3.

日期	版本	修改内容