

SPECIFICATIONS

CUSTOMER : _____

SAMPLE CODE : GFT057CA640480Y

DRAWING NO. : _____

DATE : 2008.12.04

CERTIFICATION : ROHS

Customer Sign	Sales Sign	Approved By	Prepared By

Revision Record

Data(y/m/d)	Ver.	Description	Note	page
2008.12.04	00	New		
2009.06.16	01	Add CONNECT DRAWING		19

CONTENTS

No.	ITEM	PAGE
0	CONTENTS	3
1	SUMMARY	4
2	FEATURES	4
3	GENERAL SPECIFICATIONS	4
4	ABSOLUTE MAXIMUM RATINGS	4
5	ELECTRICAL CHARACTERISTICS	5
6	DC CHARACTERISTICS	6
7	AC CHARACTERISTICS	6~8
8	OPTICAL CHARACTERISTIC	9~11
9	TOUCH PANEL	12~13
10	INTERFACE	14~15
11	BLOCK DIAGRAM	16
12	QUALITY ASSURANCE	17
13	OUTLINE DRAWING	18~19
14	PACKAGE INFORMATION	20
15	PRECAUTIONS	21~22

1. SUMMARY

This technical specification applies to 5.7" color TFT-LCD panel. The 5.7" color TFT-LCD panel is designed for Industrial Display, Instrument, Game Machine application and other electronic products which require high quality flat panel displays.

This module follows RoHS.

2. FEATURES

High Resolution: 921,600 Dots (640 RGB x 480). Image Reversion: Up/Down and Left/Right.

3. GENERAL SPECIFICATIONS

Parameter	Specifications	Unit
Screen Size	5.7(Diagonal)	inch
Display Format	640RGB x 480	Dot
Active Area	115.20(H) x 86.40(V)	mm
Pixel Pitch	0.120(H) x 0.120(V)	mm
Pixel Configuration	RGB-Stripe	
Outline Dimension	125.00(W) x 98.80(H) x 7.09(D)	mm

Weight		130 Typical	g
View Angle Direction		12 o'clock	
Temperature Range	Operation	-20~70	°C
	Storage	-30~80	°C

4. ABSOLUTE MAXIMUM RATINGS

Item	Symbol	Values		Unit	Condition
		Min.	Max.		
Digital Power Voltage	D_VDD	-0.3	+7.0	V	VSS=0
Analog Power Voltage	A_VDD	-0.3	+13.5		
Logic Input Signal	Vin	-0.3	VDD+0.3	V	
Logic Output Signal	Vout	-0.3	VDD+0.3	V	

Note: Device is subject to be damaged permanently if stresses beyond those absolute maximum ratings listed above.

5. ELECTRICAL CHARACTERISTICS

5.1. Operating conditions:

Item	Symbol	Values			Unit	Remark
		Min.	Typ.	Max.		
Digital Power Supply	VDD	3.0	3.3	3.6	V	
Digital Operating Current	IVDD	-	6.5	-	mA	
Analog Power Supply	AVDD	7.5	8.4	9.5	V	
Analog Operating Current	IAVDD	-	15	-	MA	
Power Supply	VGH	13.5	15	16.5	V	
	VGL	-11	-10	-9	V	
Power Consumption	PLCD	-	164	-	mW	

5.2 LED driving conditions

Item	Symbol	Values			Unit	Remark
		Min.	Typ.	Max.		
Power Consumption	PLE	-	1320	-	mW	
LED Current	If	-	66	-	mA	
Backlight Voltage	Vb	-	22	24.5	V	

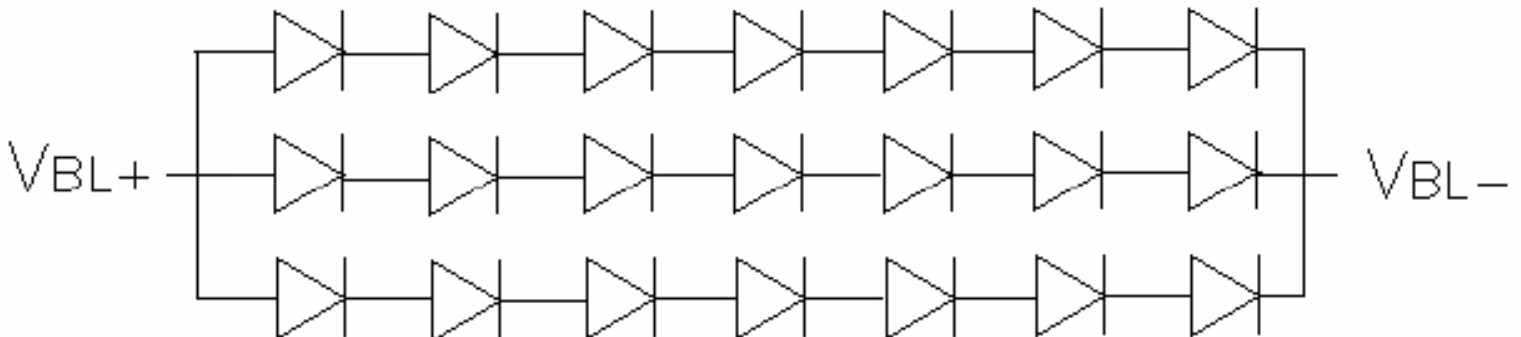

6. DC CHARACTERISTICS

Parameter	Symbol	Rating			Unit	Condition
		Min.	Typ.	Max.		
Low level input voltage	VIL	0	-	0.3*D_VDD	V	
High level input voltage	VIH	0.7*D_VDD	-	D_VDD	V	
Analog operating current	IA_VDD		15		mA	
Logic operating current	ID_VDD		6.5		mA	

7. AC CHARACTERISTICS

7.1 AC Timing Characteristics

Signal	Item	Symbol	Min.	Typ.	Max.	Unit
Dclk	CLK Frequency	FCLK	-	25.175	-	MHz
	CLK Period	TCLK	-	39.7	-	ns
	CLK Pulse Duty	TWCH/TWCL	40	50	60	%
Hsync	HS Period	TH	-	800	-	TCLK
	Horizontal Display Time	TDEH		640		TCLK
	HS Pulse Width	THS	-	6	-	TCLK
	Horizontal Back Porch	THBP	-	138	-	TCLK
	Horizontal Front Porch	THFP	-	16	-	TCLK
Vsync	VS Period	TV	-	525	-	TH
	Vertical Display Time	TVDE		480		TH
	VS Pulse Width	TVS	-	3	-	TH
	Vertical Back Porch	TVBP	-	32	-	TH
	Vertical Front Porch	TVFP	-	10	-	TH

7.2 AC Timing Diagrams

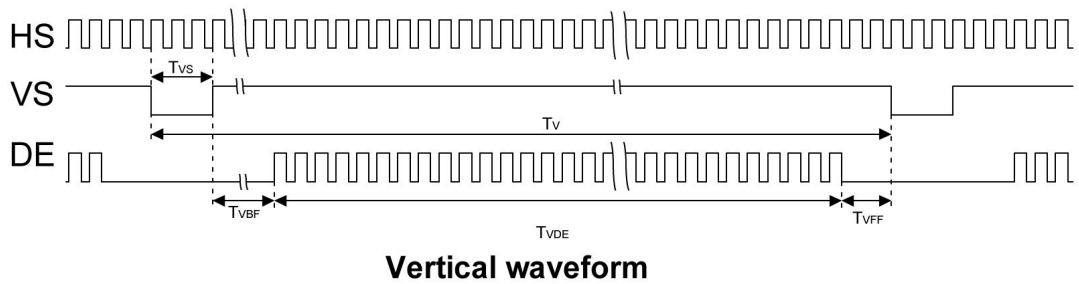
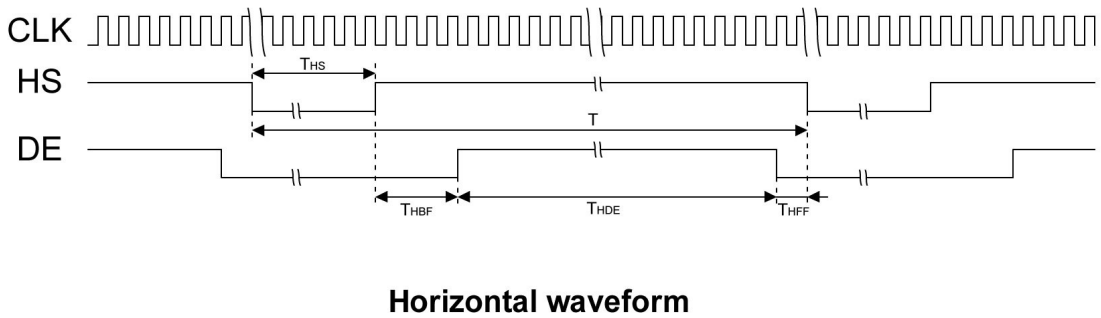
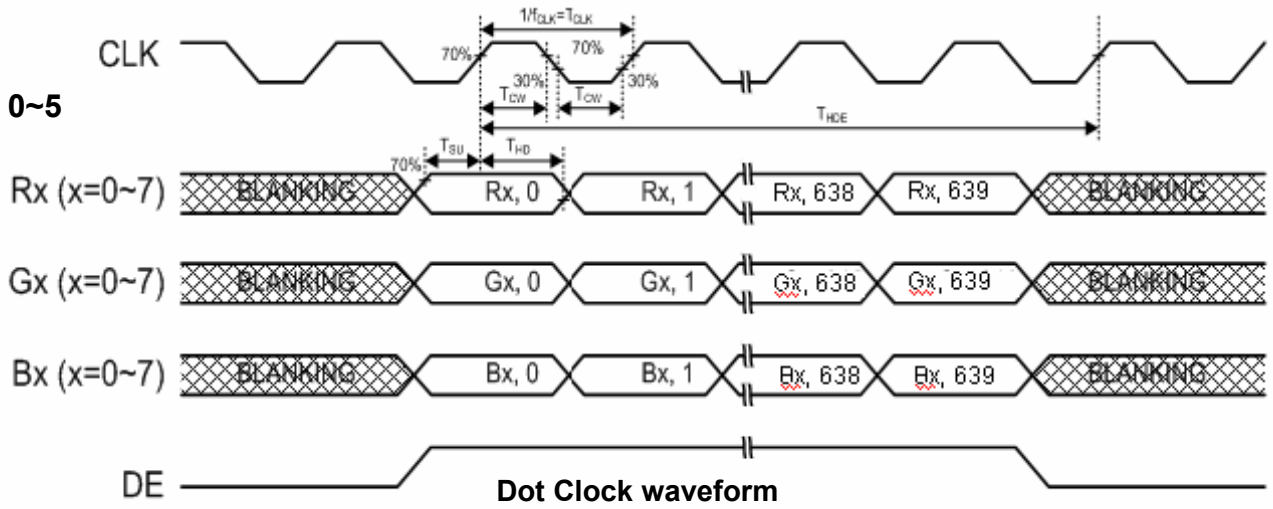

7.3 Power Sequence

The LCD panel power ON/OFF sequence is as below.

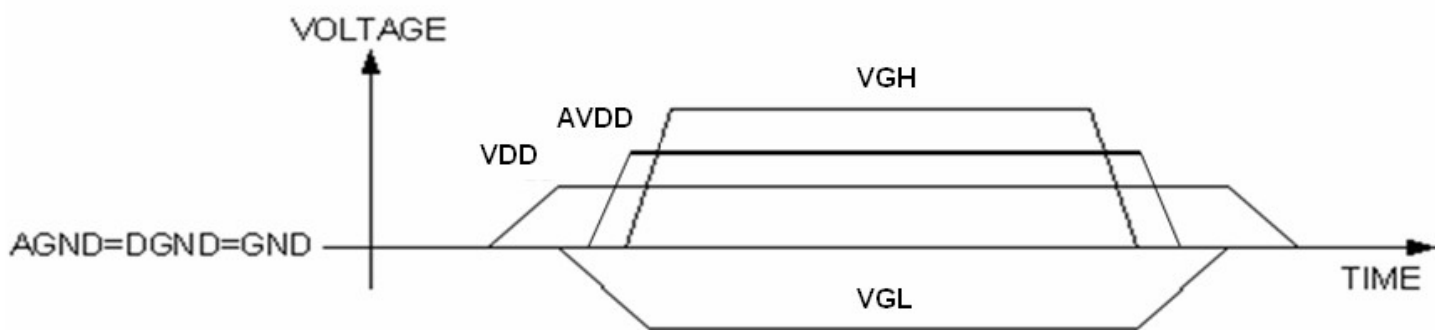

7.4 Reset Function

The driver IC is internally initialized by the global reset signal, RESETB. The reset input must be held for at least 1ms after power is stable.

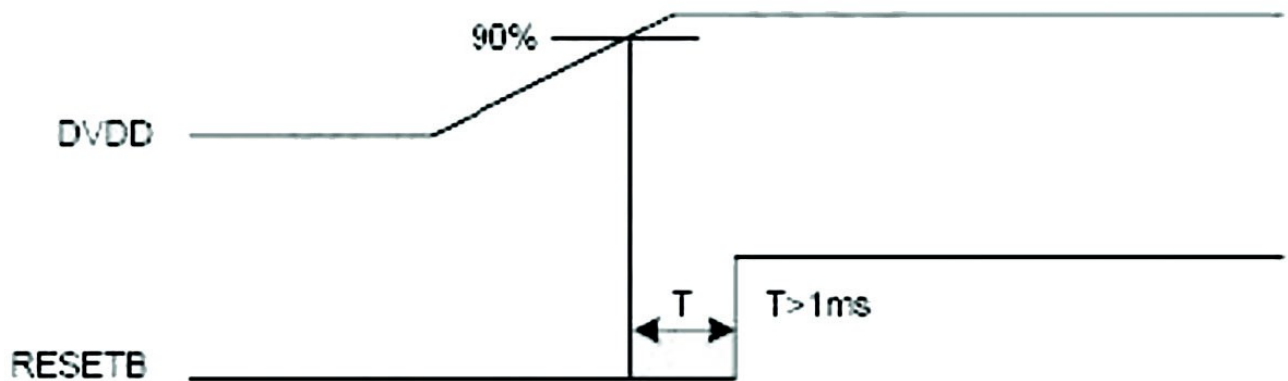

8. OPTICAL CHARACTERISTIC

Item		Symbol	Condition	Min	Typ	Max	Unit	Note
Brightness				270	300	-	cd/m ²	
Response time		TR	$\Theta=0$	-	15	-	ms	(2)
		TF		-	35	-	ms	
Contrast ratio		CR	At optimized viewing angle	300	350	-		(3)
Color Chromaticity	White	Wx	$\Theta=0$	0.26	0.31	0.36	%	(4)
		Wy		0.28	0.33	0.38		
Viewing Angle	Hor	Θ_R	$CR \geq 10$	50	60	-	Degree	(5)
		Θ_L		50	60	-		
	Ver	ψ_H		40	60	-		
		ψ_L		45	45	-		

Ta=25±2°C, ILED=20mA

Note 1: Definition of viewing angle range

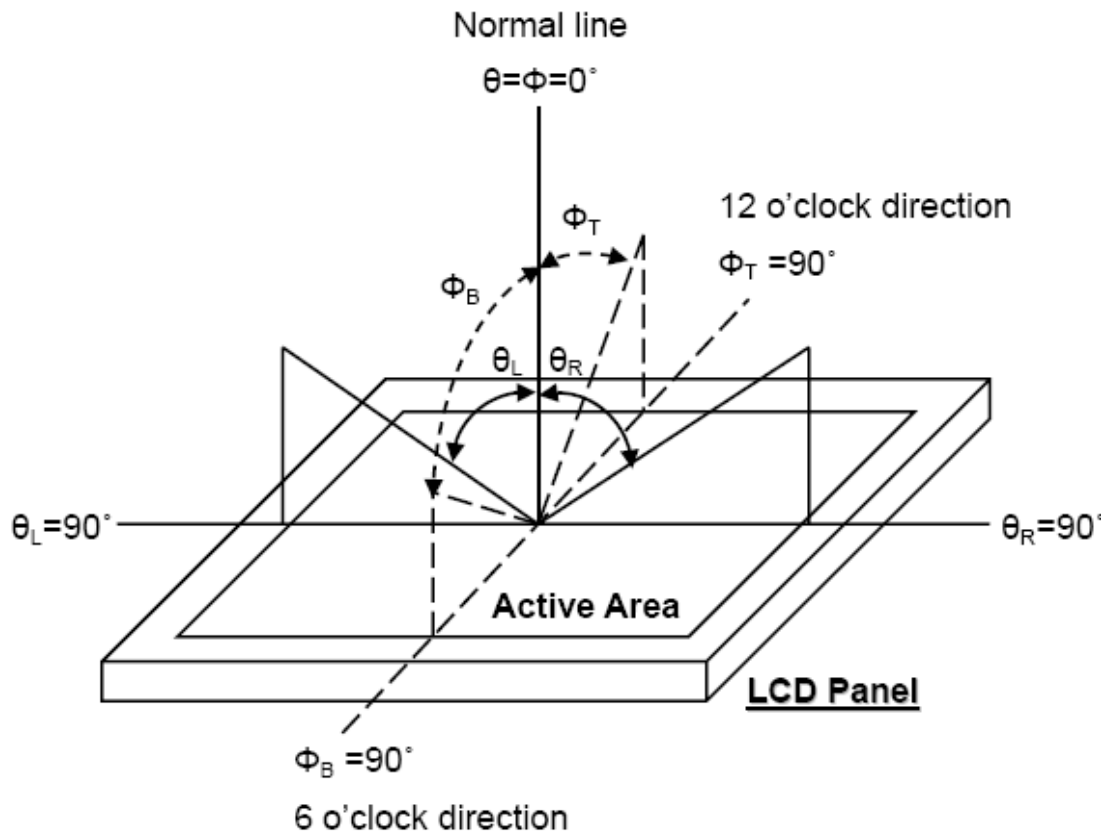

Fig. 8-1 Definition of viewing angle

Note 2: Test equipment setup:

After stabilizing and leaving the panel alone at a driven temperature for 10 minutes, the measurement should be executed. Measurement should be executed in a stable, windless, and dark room. Optical specifications are measured by Topcon BM-7 luminance meter 1.0° field of view at a distance of 50cm and normal direction.

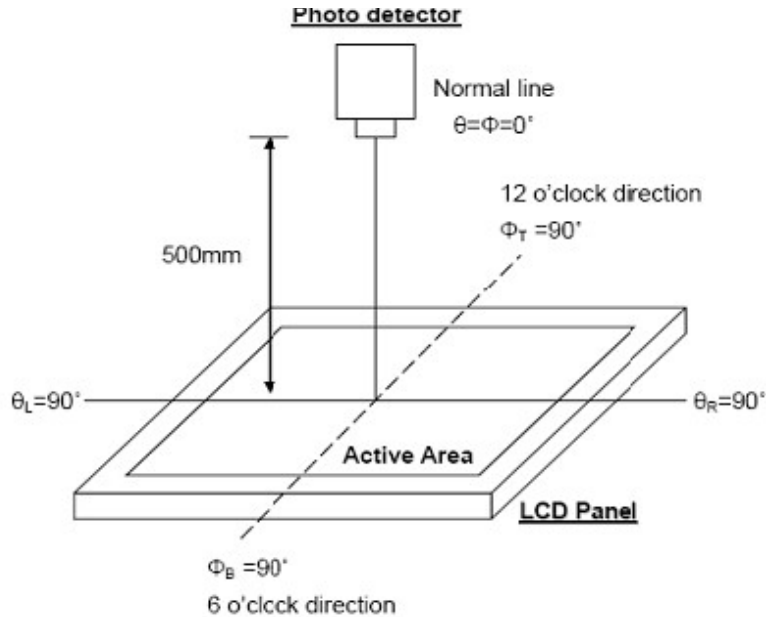

Fig. 8-2 Optical measurement system setup

Note 3: Definition of Response time:

The response time is defined as the LCD optical switching time interval between “White” state and “Black” state. Rise time, T_r , is the time between photo detector output intensity changed from 90% to 10%. And fall time, T_f , is the time between photo detector output intensity changed from 10% to 90%

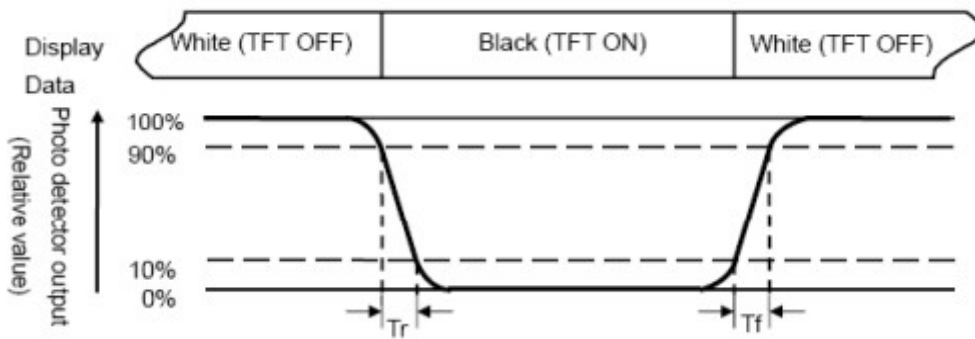

Fig. 3-3 Definition of response time

Note 4: Definition of contrast ratio:

The contrast ratio is defined as the following expression.

$$\text{Contrast ratio (CR)} = \frac{\text{Luminance measured when LCD on the "White" state}}{\text{Luminance measured when LCD on the "Black" state}}$$

Note 5: White $V_i = V_{i50} \pm 1.5V$

Black $V_i = V_{i50} \pm 2.0V$

“±” means that the analog input signal swings in phase with VCOM signal.

“±” means that the analog input signal swings out of phase with VCOM signal.

The 100% transmission is defined as the transmission of LCD panel when all the input terminals of module are electrically opened.

Note 6: Definition of color chromaticity (CIE 1931)

Color coordinates measured at the center point of LCD

Note 7: Measured at the center area of the panel when all the input terminals of LCD panel are electrically opened.

Note 8 : Uniformity (U) =
$$\frac{\text{Brightness (min)}}{\text{Brightness (max)}} \times 100\%$$

9 TOUCH PANEL

9.1 Block diagram

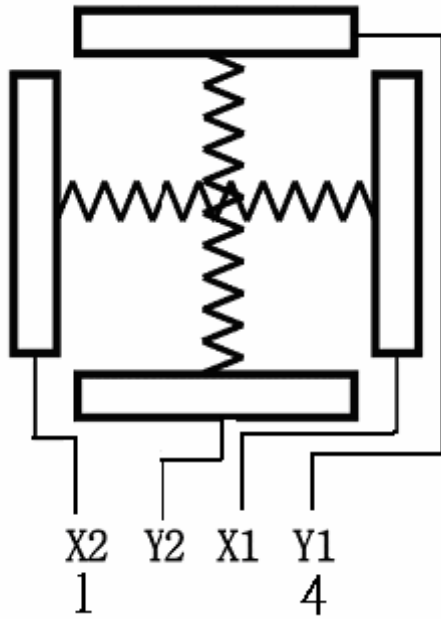

Top View

X : Upper electrode
Y : Lower electrode

Pin	Symbol	I/O	Function
1	X2	Left	Left electrode – differential analog
2	Y2	Bottom	Left electrode – differential analog
3	X1	Right	Right electrode - differential analog
4	Y1	Top	Bottom electrode - differential analog

9.3 Electrical characteristics

Item	Min.	Typ.	Max.	Unit	Note
Linearity	-	-	1.5	%	
Terminal Resistance	200	-	900	Ω	X (Film side)
	200	-	900	Ω	Y (Film side)
Insulation resistance	20	-	-	M Ω	At DC 25V
Voltage	-	-	5	V	DC
Chattering	-	-	10	ms	ON/OFF
Transparency	-	78	-	%	Non-glare
Haze rate	-	-	7	%	

Note: Do not operate it with a thing except a polyacetal pen (tip R0.8mm or less) or a finger, especially those with hard or sharp tips such as a ball point pen or a mechanical pencil.

9.4 Mechanical characteristics

Item	Min.	Typ.	Max.	Unit	Note
Activation force	-	-	1.5	%	(1)
Durability-surface scratching	Write	-	900	characters	(2)
	100,000				
Durability-surface pitting	1,000,000	-	-	touches	(3)
Surface hardness	3	-	5	H	JIS K5400, ASTM D3363

Note1: Stylus pen Input : R0.8mm polyacetal pen or Finger

Note2: Measurement for Surface area

- Scratch 100,000 times straight lines on the Film with a stylus change every 20,000times.
- Force= 150gf. Speed= 60mm/sec.
- Stylus= R0.8 polyacetal tip.

Note3: Pit 1,000,000 times on the Film with a R8.0 silicon rubber

10. INTERFACE

10.1. LCM PIN Definition

Pin	Symbol	I/O	I/O Function	Remark
1	DGND	I	Digital Ground	
2	VDD	I	Digital Power. Connected to 3.3V.	
3	VDD	I	Digital Power. Connected to 3.3V.	
4	DGND	I	Digital Ground	
5	VGL	I	Negative Power for Gate Driver. TFT gate off voltage.	
6	DGND	I	Digital Ground	
7	VGH	I	Positive Power for Gate Driver. TFT gate on voltage.	

8	DGND	I	Digital Ground	
9	UD	I	UP/DOWN Scan Control. Screen vertical flip selection.	Note 1
10	LR	I	LEFT/RIGHT Scan Control. Screen horizontal flip selection.	Note 1
11	SPENA	I	Serial port Data Enable Signal. Normally Pull high.	
12	SPCK	I	Serial port Clock. Normally pull high.	
13	SPCA	I/O	Serial port Data input/output. Normally pull high.	
14	NC	-	Not Connected	
15	DGND	I	Digital Ground	
16	B5	I	Blue Data (MSB)	
17	B4	I	Blue Data	
18	B3	I	Blue Data	
19	B2	I	Blue Data	
20	B1	I	Blue Data	
21	B0	I	Blue Data (LSB)	
22	TOP	I	Terminal Resistance	
23	RIGHT	I	Terminal Resistance	
24	DGND	I	Digital Ground	
25	G5	I	Green Data (MSB)	
26	G4	I	Green Data	
27	G3	I	Green Data	
28	G2	I	Green Data	
29	G1	I	Green Data	
30	G0	I	Green Data (LSB)	
31	BOTTOM	I	Terminal Resistance	
32	LEFT	I	Terminal Resistance	
33	AGND	I	Analog Ground	
34	AVDD	I	Analog Power. Connected to 8.4V.	
35	AVDD	I	Analog Power. Connected to 8.4V.	
36	AGND	I	Analog Ground	
37	R5	I	Red Data (MSB)	
38	R4	I	Red Data	
39	R3	I	Red Data	
40	R2	I	Red Data	
41	R1	I	Red Data	
42	R0	I	Red Data (LSB)	
43	DGND	I	Digital Ground	
44	DGND	I	Digital Ground	
45	DE	I	Display Data Enable Signal Input. Pull low if unused.	
46	CLK	I	Clock Signal Input. Latching data at the rising edge.	
47	HS	I	Horizontal Synchronization Signal Input.	
48	VS	I	Vertical Synchronization Signal Input.	
49	VCOM	I	Common Electrode Driving Input.	
50	DGND	I	Digital Ground	

Note: The UD and LR control the display direction of the panel. The settings of UD and LR are as following:



UD=VDD, LR=GND



UD=VDD, LR=VDD



UD=GND, LR=GND



UD=GND, LR= VDD

11. BLOCK DIAGRAM

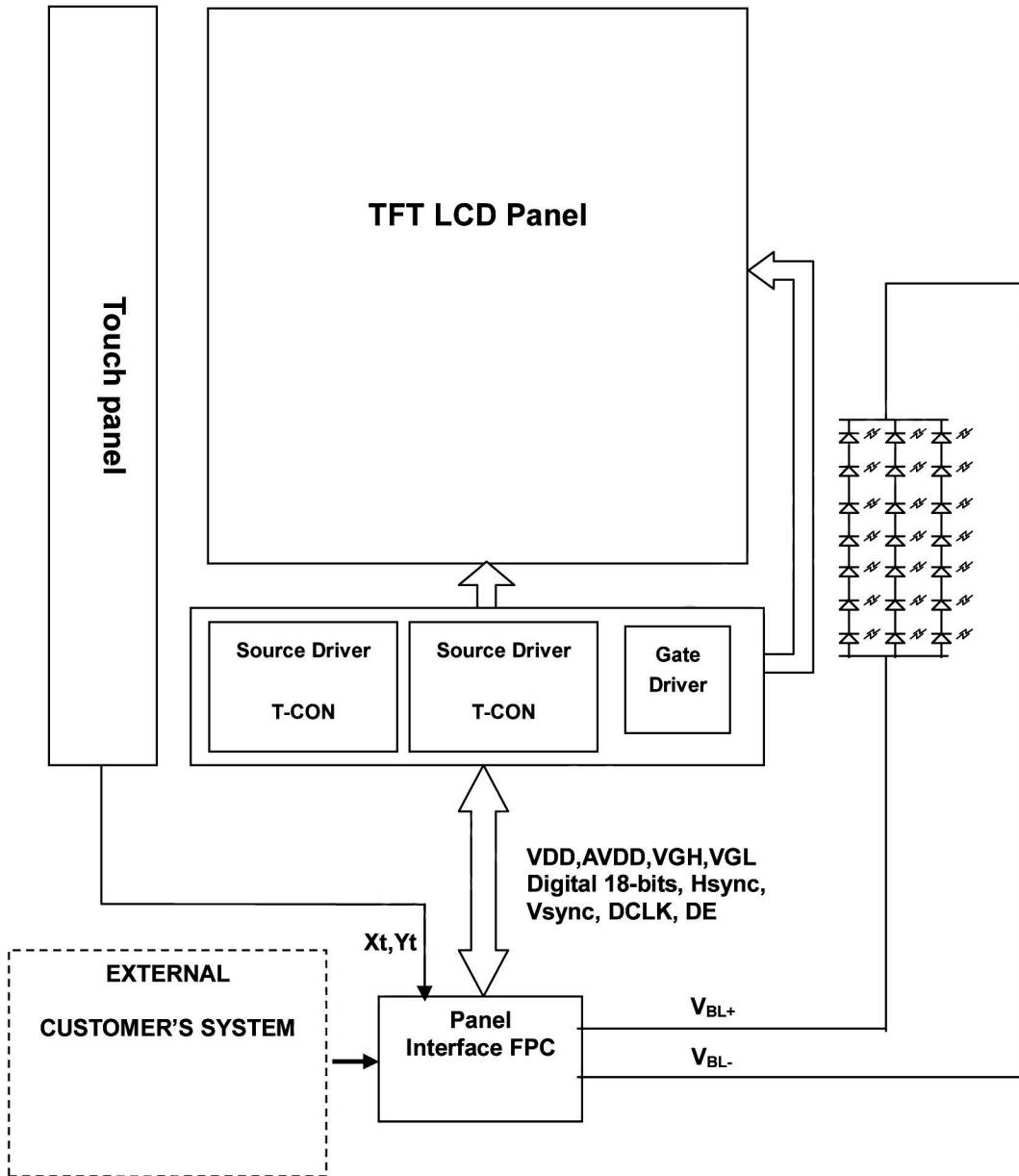

12.QUALITY ASSURANCE

No.	Test Item	Test Condition	REMARK
1	High Temperature Storage Test	Ta=80°C Dry 240h	
2	Low Temperature Storage Test	Ta=-30°C Dry 240h	
3	High Temperature Operation Test	Ta=70°C Dry 240h	
4	Low Temperature Operation Test	Ta=-20°C Dry 240h	
5	High Temperature and High Humidity Operation Test	Ta=60°C 90%RH 240h	
6	Electro Static Discharge Test	Panel surface / top case Contact / Air : 8KV / ±15KV , 150Pf , 330Ω	Non-operating
7	Shock Test (non-operating)	Shock Level : 100G Waveform : Half Sinusoidal Wave Shock Time : 6ms Number of Shocks : 3 times for each ±X, ±Y, ±Z direction	
8	Vibration Test (non-operating)	Frequency Range: 10~55Hz. Amplitude:1.5 mm. Sweep Time: 11min. Test Period : 6 cycles for each direction of X,Y,Z	
9	Thermal Shock Test		

Note1: The test samples have recovery time for 2 hours at room temperature before the function check. In the standard conditions, there is no display function NG issue occurred.

Note2: All the cosmetic specifications are judged before the reliability stress.

13.OUTLINE DRAWING



12.1 CONNECT DRAWING

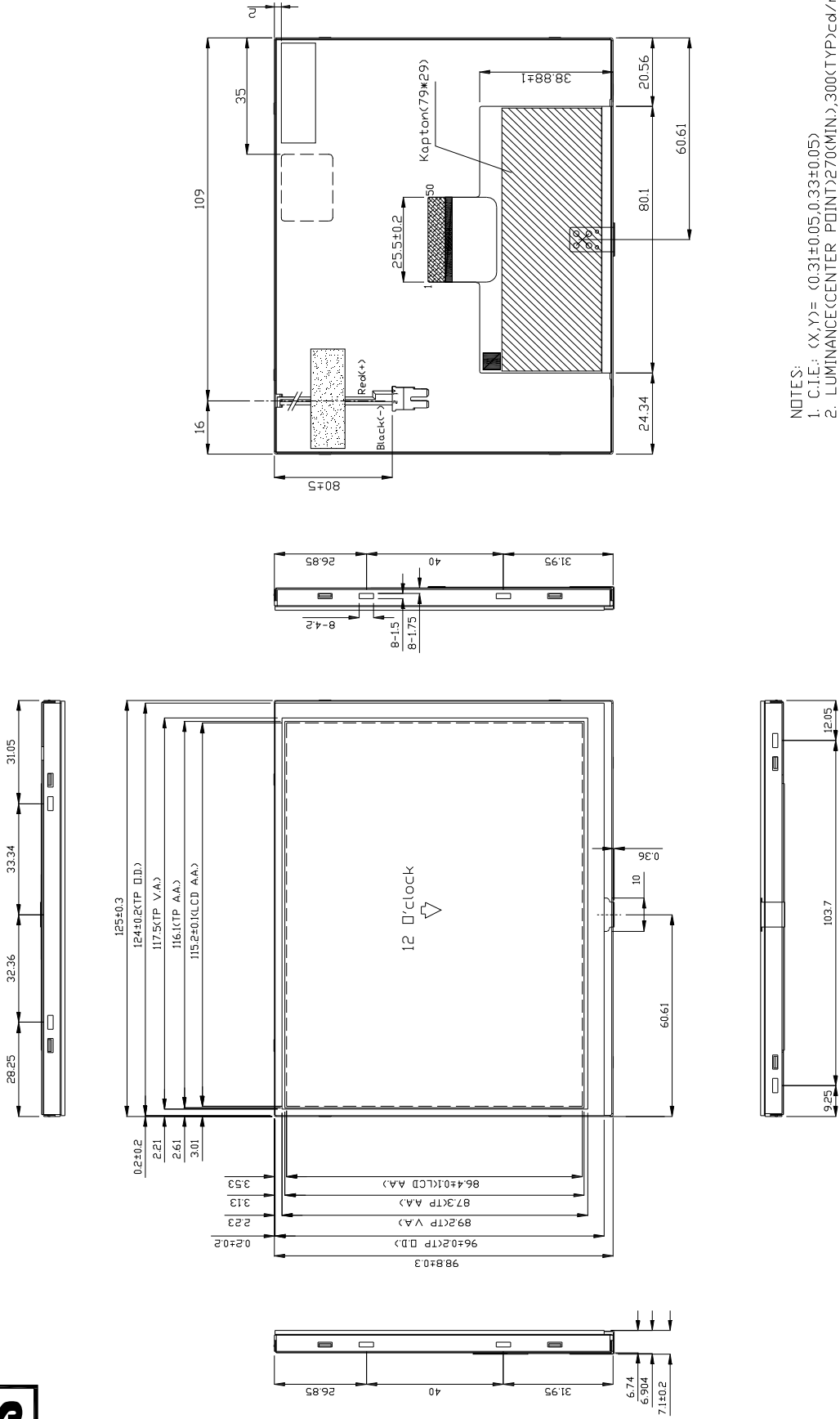

- NOTES:
1. C.I.E: (X,Y)= (0.31±0.05,0.33±0.05)
 2. LUMINANCE(CENTER POINT)≥270(MIN.),300(TYP)>cd/m²
 3. UNIFORMITY=70%(MIN.),75%(TYP)
 4. FORWARD CURRENT= 60mA(MAX.)VOLTAGE=23.1V~24.5V
 5. B/L 平整度 ±0.2mm.

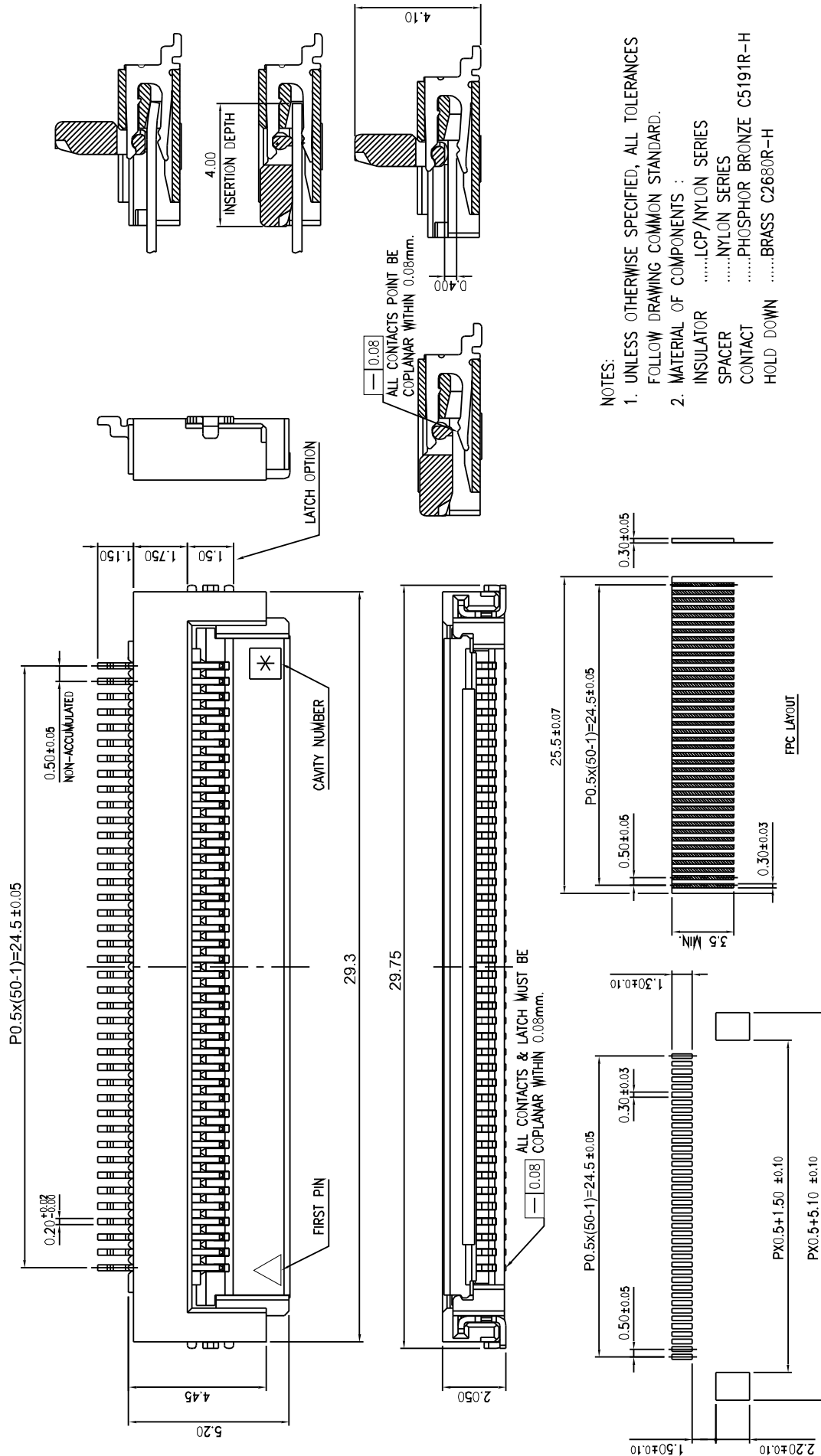

- NOTES:
- UNLESS OTHERWISE SPECIFIED, ALL TOLERANCES FOLLOW DRAWING COMMON STANDARD.
 - MATERIAL OF COMPONENTS :
 - INSULATORLCP/NYLON SERIES
 - SPACERNYLON SERIES
 - CONTACTPHOSPHOR BRONZE C5191R-H
 - HOLD DOWNBRASS C2680R-H

RECOMMENDED P.C. BOARD PATTERN LAYOUT
 RECOMMENDED METAL MASK THICKNESS: T=0.15

14.PACKAGE INFORMATION

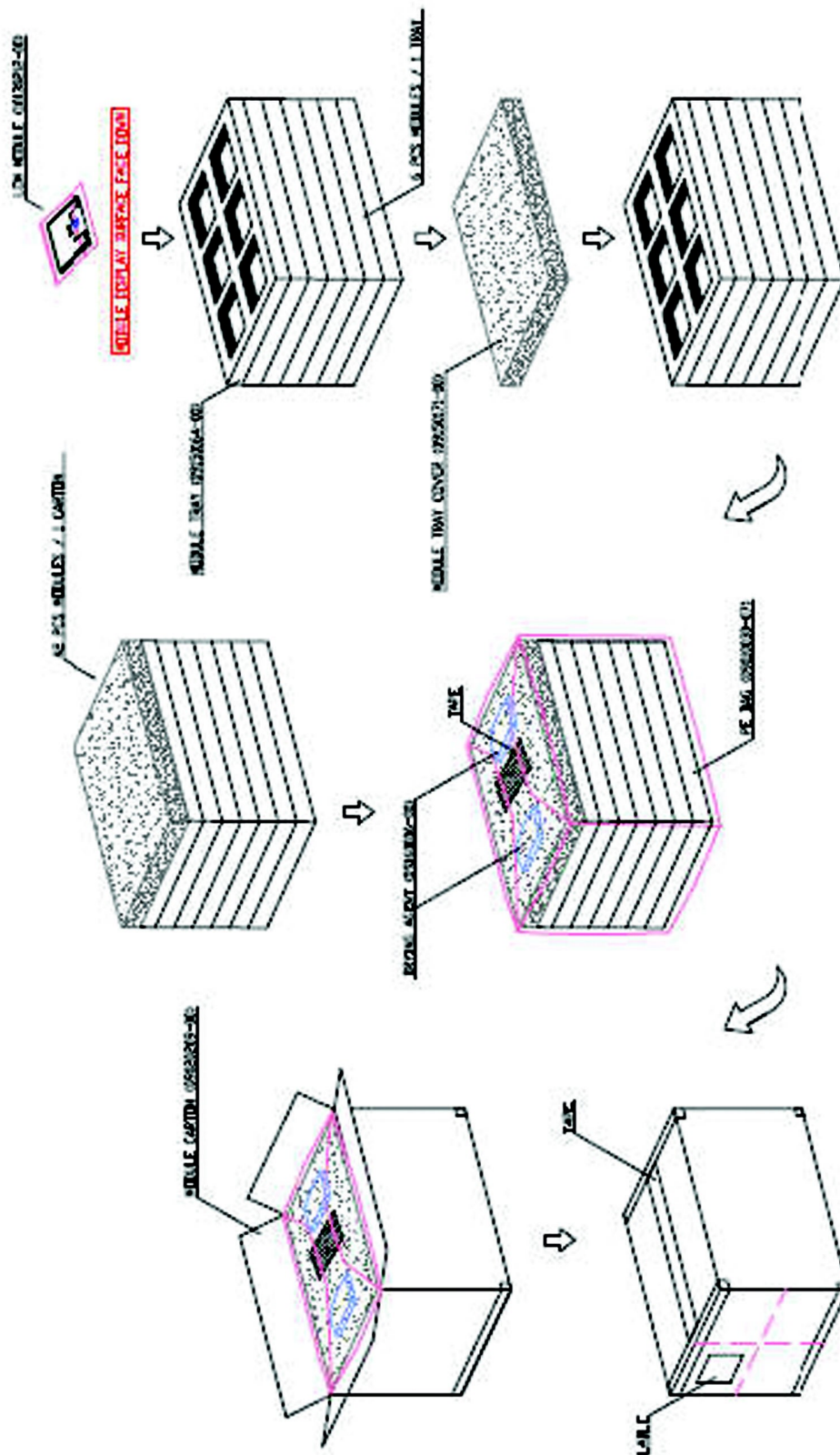

15. PRECAUTIONS

Please pay attention to the following when you use this TFT LCD module.

15.1 MOUNTING PRECAUTIONS

- (1) You must mount a module using arranged in four corners or four sides.
- (2) You should consider the mounting structure so that uneven force (ex. Twisted stress) is not applied to the module.
And the case on which a module is mounted should have sufficient strength so that external force is not transmitted directly to the module.
- (3) Please attach a transparent protective plate to the surface in order to protect the polarizer.
Transparent protective plate should have sufficient strength in order to the resist external force.
- (4) You should adopt radiation structure to satisfy the temperature specification.
- (5) Acetic acid type and chlorine type materials for the cover case are not describe because the former generates corrosive gas of attacking the polarizer at high temperature and the latter causes circuit break by electro-chemical reaction.
- (6) Do not touch, push or rub the exposed polarizers with glass, tweezers or anything harder than HB pencil lead. And please do not rub with dust clothes with chemical treatment.
Do not touch the surface of polarizer for bare hand or greasy cloth. (Some cosmetics are determined to the polarizer)
- (7) When the surface becomes dusty, please wipe gently with adsorbent cotton or other soft materials like chamois soaks with petroleum benzene. Normal-hexane is recommended for cleaning the adhesives used to attach front / rear polarizers. Do not use acetone, toluene and alcohol because they cause chemical damage to the polarizer.
- (8) Wipe off saliva or water drops as soon as possible. Their long time contact with polarizer causes deformations and color fading.
- (9) Do not open the case because inside circuits do not have sufficient strength.

15.2 OPERATING PRECAUTIONS

- (1) The spike noise causes the mis-operation of circuits. It should be lower than following voltage $V = \pm 200\text{mV}$ (Over and under shoot voltage)
- (2) Response time depends on the temperature. (In lower temperature, it becomes longer.)
- (3) Brightness depends on the temperature. (In lower temperature, it becomes lower)
And in lower temperature, response time (required time that brightness is stable after turned on) becomes longer.
- (4) Be careful for condensation at sudden temperature change. Condensation makes damage to polarizer or electrical contacted parts. And after fading condensation, smear or spot will occur.
- (5) When fixed patterns are displayed for a long time, remnant image is likely to occur.
- (6) Module has high frequency circuits. Sufficient suppression to the electromagnetic interference shall be done by system manufacturers. Grounding and shielding methods may be important to minimize the interference.

15.3 ELECTROSTATIC DISCHARGE CONTROL

Since a module is composed of electronic circuits, it is not strong to electrostatic discharge. Make certain that treatment persons are connected to ground through wristband etc. And don't touch interface pin directly.

15.4 PRECAUTIONS FOR STRONG LIGHT EXPOSURE

Strong light exposure causes degradation of polarizer and color filter.

15.5 STORAGE

When storing modules as spares for a long time, the following precautions are necessary.

- (1) Store them in a dark place. Do not expose the module to sunlight or fluorescent light. Keep the temperature between 5 and 35 __ at normal humidity.
- (2) The polarizer surface should not come in contact with any other object. It is recommended