

SPECIFICATIONS

CUSTOMER : _____

SAMPLE CODE : GFT070BB800480-DLY

DRAWING NO. : _____

DATE : 2009.04.02

CERTIFICATION : ROHS

Customer Sign	Sales Sign	Approved By	Prepared By

Revision Record

Data(y/m/d)	Ver.	Description	Note	page
2009.04.02	00	New		20

Color Pixel Arrangement	RGB vertical stripe
Display Mode	Normally white
Number of colors	262,144
Brightness (cd/m ²)	250nit (typ)
NTSC ratio	50%
Response Time (Tr+Tf)	30ms
Outline Dimension (in mm)	165.0(W)*104.0(H)*9.5(D)(with Touch panel, With T-con)
Viewing Angle (BL on,CR ≥ 10)	140 degree (H), 100degree (V)
Power consumption	1.78W(Typ)
BL unit	LED
Electrical interface (data)	TTL
Viewing Direction	6 o'clock
Surface Treatment	Anti-Glare, Hardness:3H
Weight (g)	TBD

2. ABSOLUTE MAXIMUM RATINGS

Item	Symbol	Min.	Max.	Unit	Note
Power Supply Voltage	Vcc	-0.3	4.6	V	
LEDs Voltage	VL	9.6	10.2	V	
LEDs Current	IL	160	200	mAr	
Static Electricity	VESDc	-200	200	V	*1)
	VESDm	-15K	15K		
ICC Rush Current	IRUSH	-	1	A	*2)

[Note]

*1) Test Condition: IEC 61000-4-2 ,

VESDc : Contact discharge to input connector

VESDm : Contact discharge to module

*2) Control signal:High(+3.3V)→Low(GND)

Supply Voltage of rising time should be from R3 and C2 tune to 550 us.

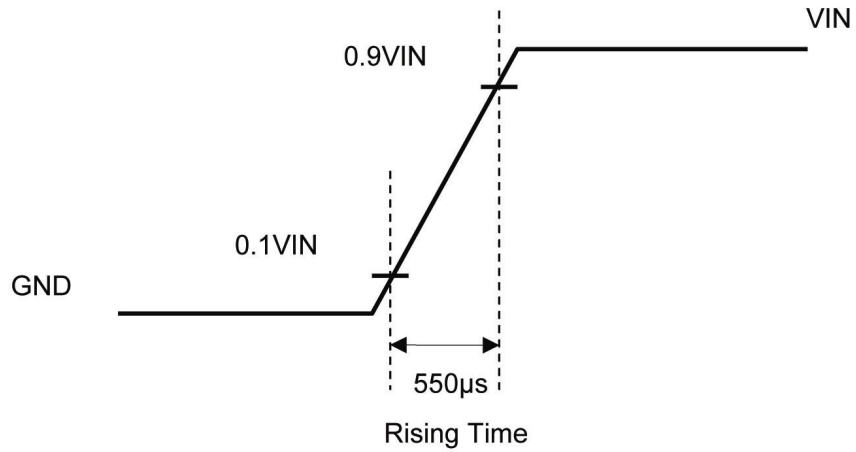
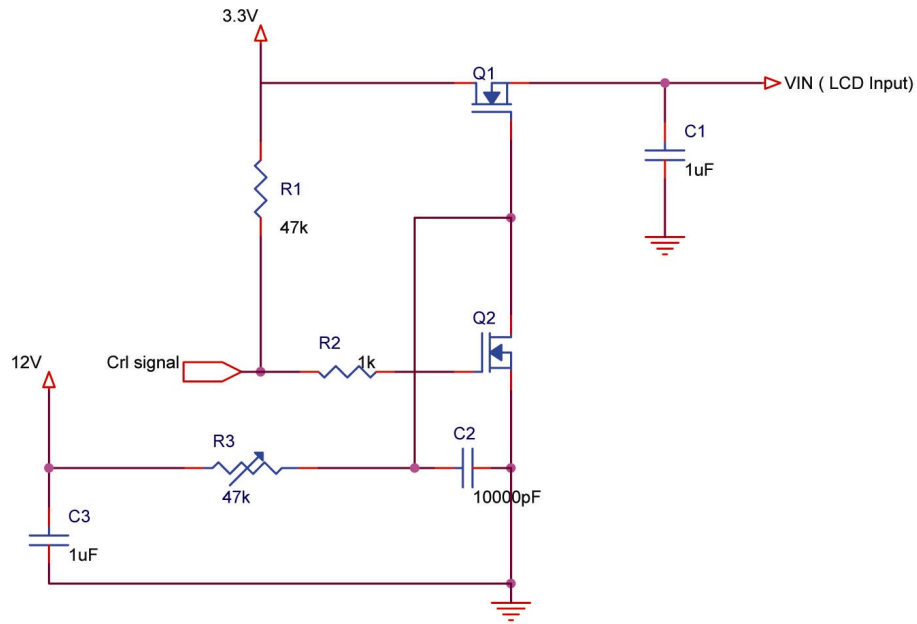

3. ELECTRICAL CHARACTERISTICS

3.1 TFT LCD

Item	Symbol	Min.	Typ	Max.	Unit	Note
PowerSupply LCD Voltage For	Vcc	3.0	3.3	3.6	V	[Note1]
Logic Input Voltage	VIH	0.7VCC	-	VCC	V	
	VIL	0	-	0.3VCC	V	

[Note1]VCC –dip codition:

- 1) When $2.7\text{ V} \leq VCC < 3.0\text{ V}$, $t_d \leq 10\text{ ms}$.
- 2) $VCC > 3.0\text{ V}$, VCC-dip condition should be same as VCC-turn-on condition.

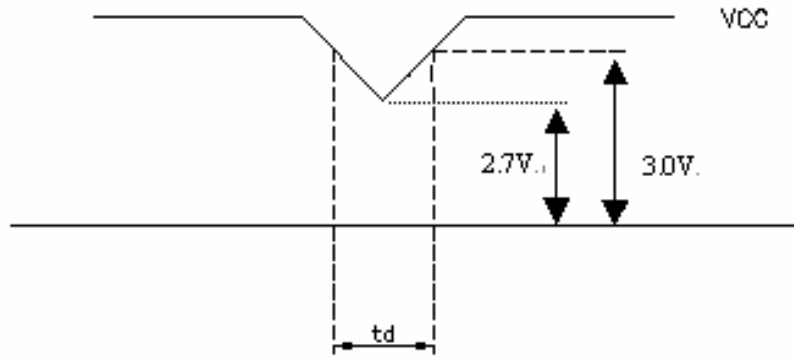

3.2 TFT LCD current consumption

Item	Symbol	Min.	Typ	Max.	Unit	Note
LCD Power Current	ICC	-	150	200	mA	【Note2】

[Note2]

Typical: Under 64 gray pattern

Maximum: Under black pattern

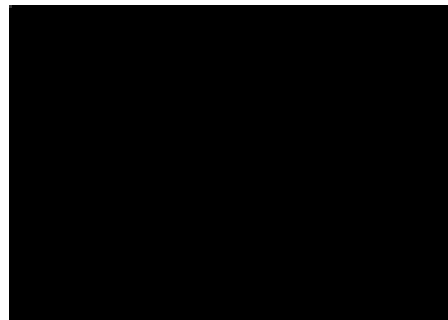
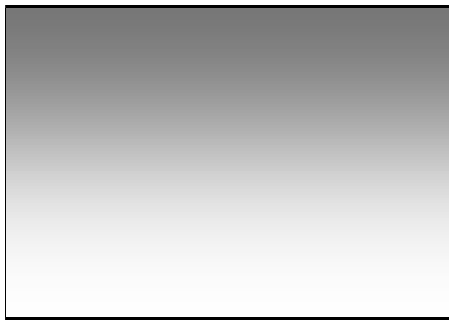

(a) 64-Gray Pattern (b) Black Pattern

3.3 Power , Signal sequence

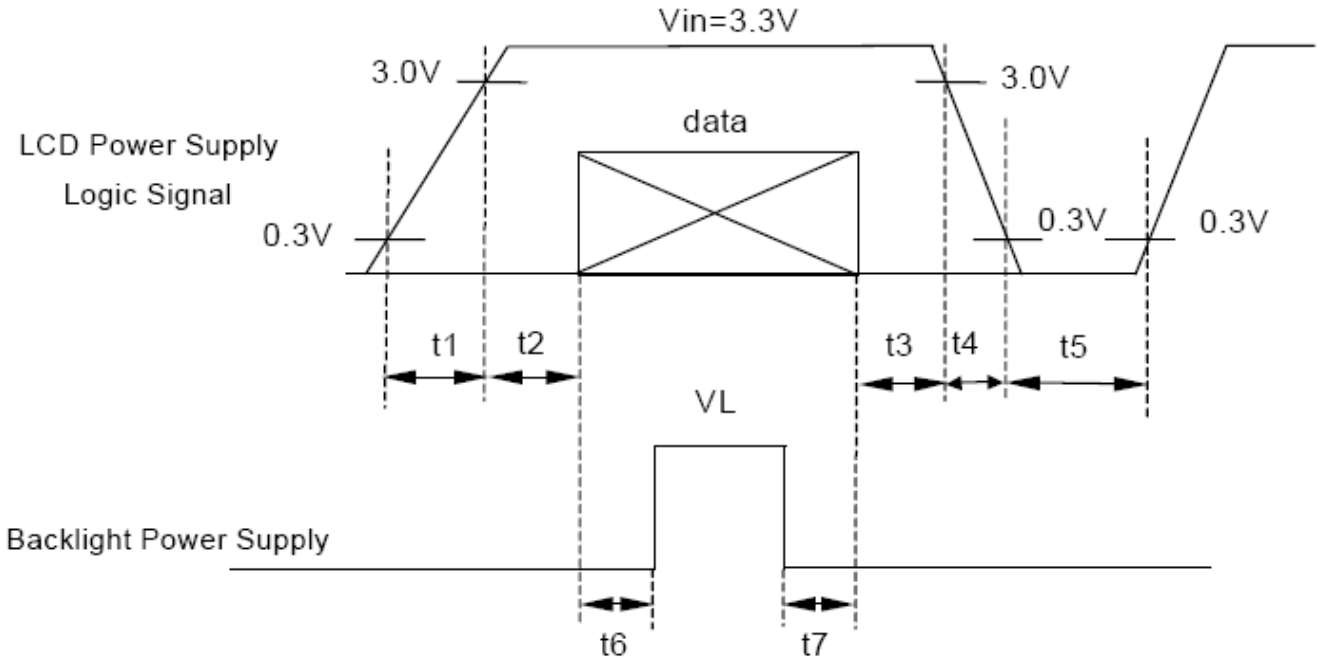

Data: RGB DATA, DCLK, DENA
 $t_1 \leq 10ms$ $1 \text{ sec} \leq t_5$
 $50ms \leq t_2$ $200ms \leq t_6$
 $0 < t_3 \leq 50ms$ $200ms \leq t_7$
 $0 < t_4 \leq 10ms$

3.4 Backlight

Item	Symbol	Min.	Typ	Max.	Unit	Note
Lamp Voltage	VL	9.6	9.9	10.2	V	*1)IL=180mA
Lamp Current	IL	160	180	200	mA	*1) *2)
LEDs life time	LT	20000	-	-	Hr	*1) *2) *3)IL=180mA , operation
Turn on and off life	-	10000	-	-	Times	*1) *2) 3)IL=180mA , operation , time cycle 30s
Start Lamp Voltage	Ta=0°C	-	-	-	Vrms	*5)
	Ta=25°C	°C	-	-		
Power Consumption	PBL	-	1.782	-	Watt	VL*IL , IL=180mA

[Note]

- (1) Table of specifications are definition of single lamp.
- (2) Lamp Current measurement method (The current meter is inserted in cold line)

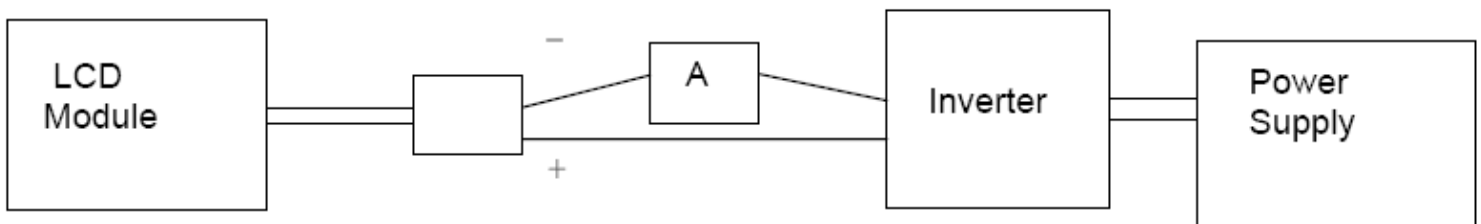

- (3) Definition of the lamp life time: Luminance (L) under 50% of specification starting lamp voltage.

- (4) 1. Frequency in this range can mala the characteristics of electric and optics maintain in +/- 10% except hue.
2. Lamp frequency of inverter may produce interference with horizontal synchronous frequency (or vertical synchronous frequency), and this may cause ripple noise on the display. Therefore, please adjust inverter frequency, and keep inverter as far from module as possible or use electronic shielding between inverter and module to avoid the interference.
- (5) 1. Starting Lamp Voltage: V_s =initial value V_s
2. Definition of starting lamp voltage means max. voltage of starting lamp. We suggest the inverter starting voltage greater then max. voltage of starting lamp to certify starting lamp stability.
- (6) If the driving waveform of lamp is asymmetric, the distribution of mercury inside the lamp tube will become unequally or will deplete the Ar gas in it. Then it may cause the abnormal phenomenon of lighting-up. Therefore, designers have to try their best to for fill the conditions under the inverter designing stage as below:

- The degrees of unbalance : $< 10\%$
The ratio of wave height : $< \sqrt{2} \pm 10\%$

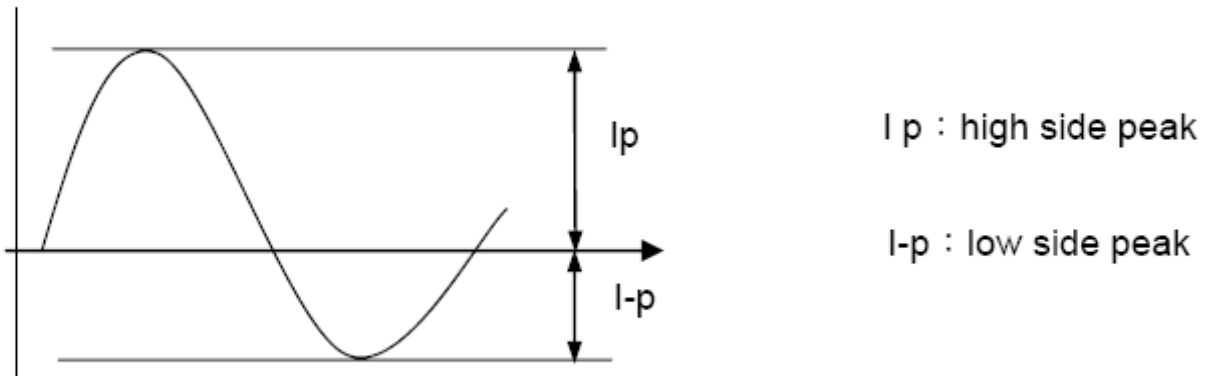

A : The degrees of unbalance = $| I_p - I-p | / I_{rms} \times 100 (\%)$
B : The ratio of wave height = I_p (or $I-p$) / I_{rms}

4. INTERFACE CONNECTOR

4.1 Connector type: 40pin / 0.5mm pitch / Bottom contact: 089N40-000R00-G2

Pin NO.	SYMBOL	DESCRIPTION
1	VSS	Ground
2	VSS	Ground

3	NC	No Connection
4	VCC	Power Supply
5	VCC	Power Supply
6	VCC	Power Supply
7	VCC	Power Supply
8	NC	No Connection
9	DE	Data Enable Timing Signal
10	VSS	Ground
11	VSS	Ground
12	VSS	Ground
13	B5	Blue Data 5 (MSB)
14	B4	Blue Data 4
15	B3	Blue Data 3
16	VSS	Ground
17	B2	Blue Data 2
18	B1	Blue Data 1
19	B0	Blue Data 0 (LSB)
20	VSS	Ground
21	G5	Green Data 5 (MSB)
22	G4	Green Data 4
23	G3	Green Data 3
24	VSS	Ground
25	G2	Green Data 2
26	G1	Green Data 1
27	G0	Green Data 0 (LSB)
28	VSS	Ground
29	R5	Red Data 5 (MSB)
30	R4	Red Data 4
31	R3	Red Data 3
32	VSS	Ground
33	R2	Red Data 2
34	R1	Red Data 1
35	R0	Red Data 0
36	VSS	Ground
37	VSS	Ground
38	DCLK	Data Clock
39	VSS	Ground
40	VSS	Ground

Remarks: 1) NC Pin must be retain, this pin can't contact GND or other signal.

2) Vss Pin must ground contact , can not be floating.

4.2 Backlight

Input connector type for back light : BHSR-02VS-1(JST)

Output connector type for Inverter: SM02-BHSS-1-TB

Pin No.	Symbol	function
---------	--------	----------

1	CTH	VBLH(High-Voltage)
2	CTL	VBLL(Low-Voltage)

[Note]:VBLH-VBLL=VL

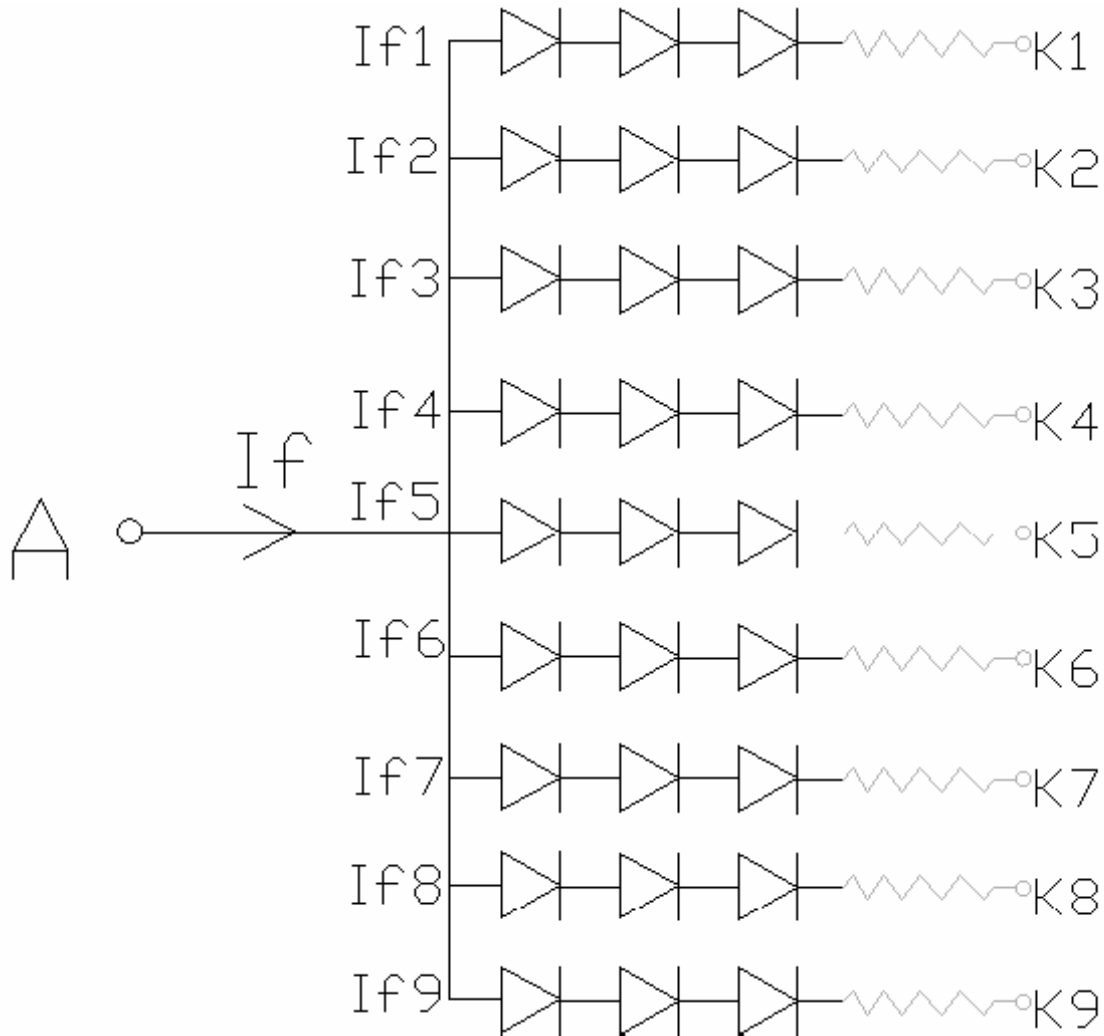

Note1: $T=25^{\circ}\text{C}$ $I_L=20\text{mA}$ (per LED) Note2: LED B/L circuit (as below figure), $I_f=180\text{mA}$, $I_{f1}=I_{f2}=I_{f3}=I_{f4}=I_{f5}=I_{f6}=I_{f7}=I_{f8}=I_{f9}=20\text{mA}$,A:Anode,K:Cathode.

5. INPUT SIGNAL (DE ONLY MODE)

5.1 Timing specification

ITEM		SYMBOL	MIN.	TYP.	MAX.	UNIT
DCLK	Period	tCLK	31	37.0	40.0	ns
	Dot Clock	fCLK	25	27	32	MHz

COLOR	INPUT DATA	R DATA						G DATA						B DATA					
		R5	R4	R3	R2	R1	R0	G5	G4	G3	G2	G1	G0	B5	B4	B3	B2	B1	B0
		MSB					LSB	MSB					LSB	MSB					LSB
BASIC COLOR	BLACK	0	0	0	0	0	0	0	0	0	0	0	0	0	0	0	0	0	0
	RED(63)	1	1	1	1	1	1	0	0	0	0	0	0	0	0	0	0	0	0
	GREEN(63)	0	0	0	0	0	0	1	1	1	1	1	1	0	0	0	0	0	0
	BLUE(63)	0	0	0	0	0	0	0	0	0	0	0	0	1	1	1	1	1	1
	CYAN	0	0	0	0	0	0	1	1	1	1	1	1	1	1	1	1	1	1
	MAGENTA	1	1	1	1	1	1	0	0	0	0	0	0	1	1	1	1	1	1
	YELLOW	1	1	1	1	1	1	1	1	1	1	1	1	0	0	0	0	0	0
	WHITE	1	1	1	1	1	1	1	1	1	1	1	1	1	1	1	1	1	1
RED	RED(0)	0	0	0	0	0	0	0	0	0	0	0	0	0	0	0	0	0	0
	RED(1)	0	0	0	0	0	1	0	0	0	0	0	0	0	0	0	0	0	0
	RED(2)	0	0	0	0	1	0	0	0	0	0	0	0	0	0	0	0	0	0
	RED(62)	1	1	1	1	1	0	0	0	0	0	0	0	0	0	0	0	0	0
	RED(63)	1	1	1	1	1	1	0	0	0	0	0	0	0	0	0	0	0	0
GREEN	GREEN(0)	0	0	0	0	0	0	0	0	0	0	0	0	0	0	0	0	0	0
	GREEN(1)	0	0	0	0	0	0	0	0	0	0	0	1	0	0	0	0	0	0
	GREEN(2)	0	0	0	0	0	0	0	0	0	0	1	0	0	0	0	0	0	0
	GREEN(62)	0	0	0	0	0	0	1	1	1	1	1	0	0	0	0	0	0	0
	GREEN(63)	0	0	0	0	0	0	1	1	1	1	1	1	0	0	0	0	0	0
BLUE	BLUE(0)	0	0	0	0	0	0	0	0	0	0	0	0	0	0	0	0	0	0
	BLUE(1)	0	0	0	0	0	0	0	0	0	0	0	0	0	0	0	0	0	1
	BLUE(2)	0	0	0	0	0	0	0	0	0	0	0	0	0	0	0	0	1	0
	BLUE(62)	0	0	0	0	0	0	0	0	0	0	0	0	1	1	1	1	1	0
	BLUE(63)	0	0	0	0	0	0	0	0	0	0	0	0	1	1	1	1	1	1

[Note]

- (1) Definition of Gray Scale
color(n) : n is series of Gray Scale
The more n value is, the bright Gray Scale.
- (2)Data:1-High,0-Low

6. BLOCK DIAGRAM

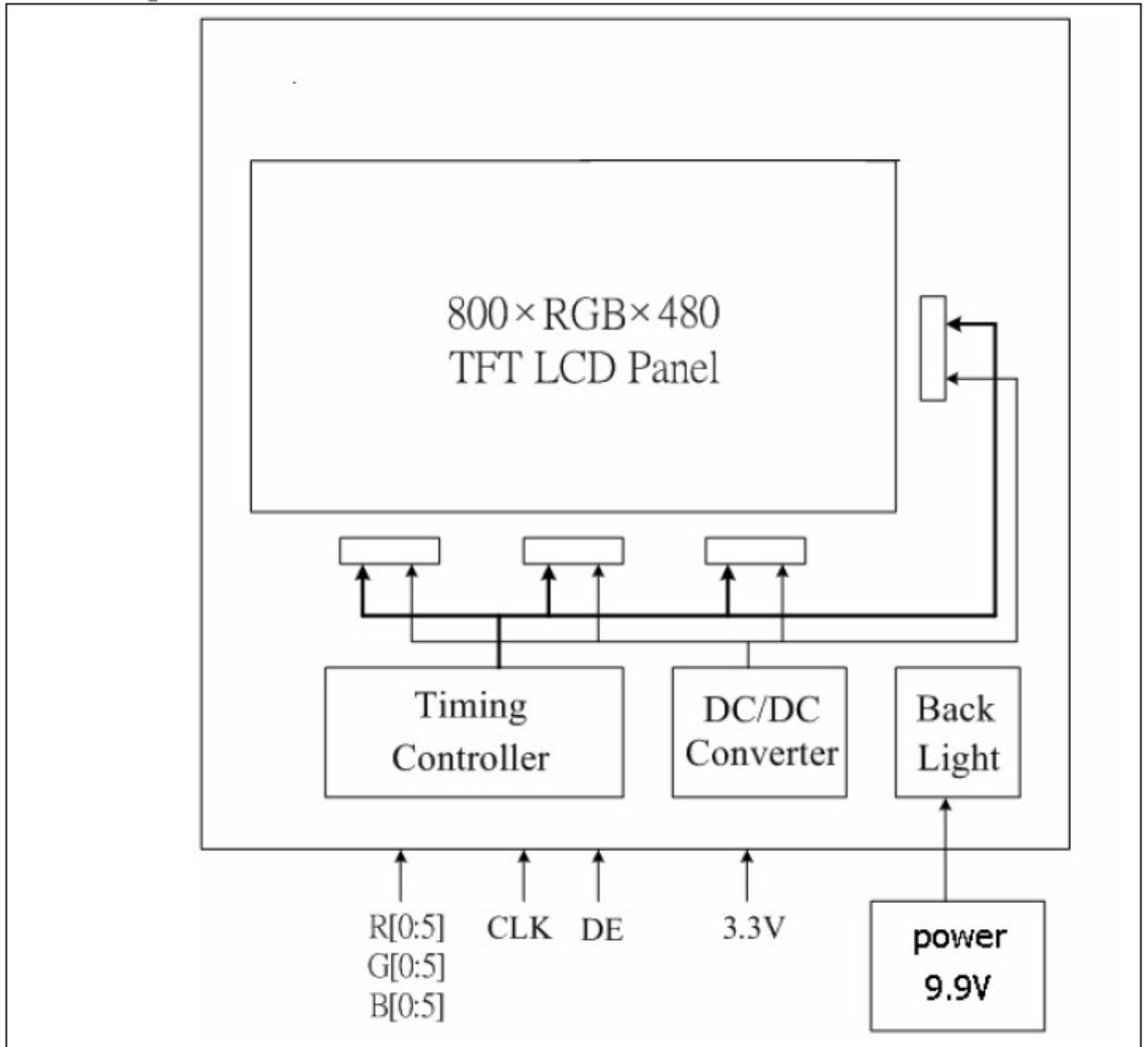

7. MECHANICAL DIMENSION

CONNECT DRAWING:

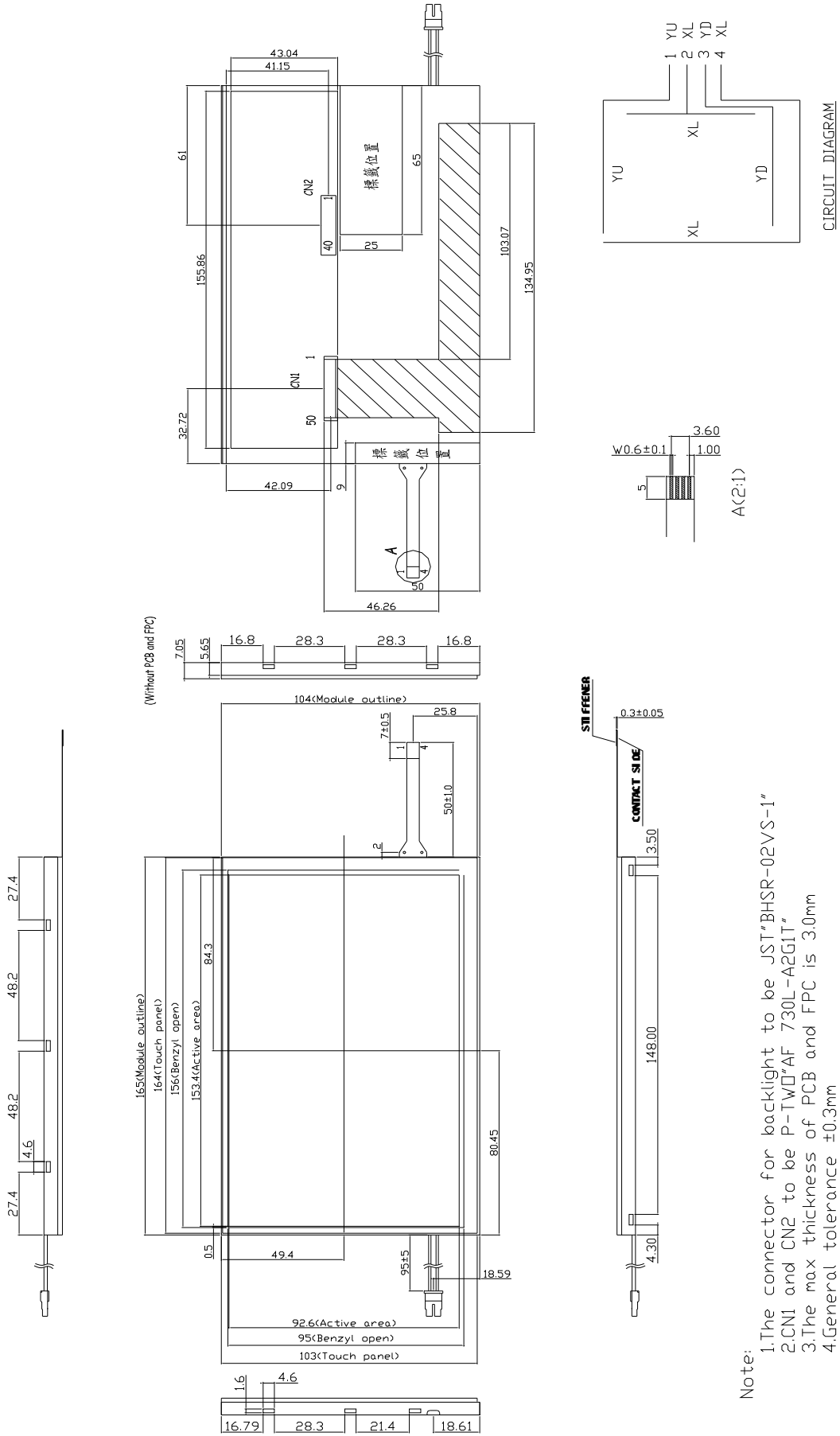

- Note:
- 1.The connector for backlight to be JST[®]BHSR-02VS-1"
 - 2.CN1 and CN2 to be P-TW07AF 730L-A2G1T"
 - 3.The max thickness of PCB and FPC is 3.0mm
 - 4.General tolerance ±0.3mm

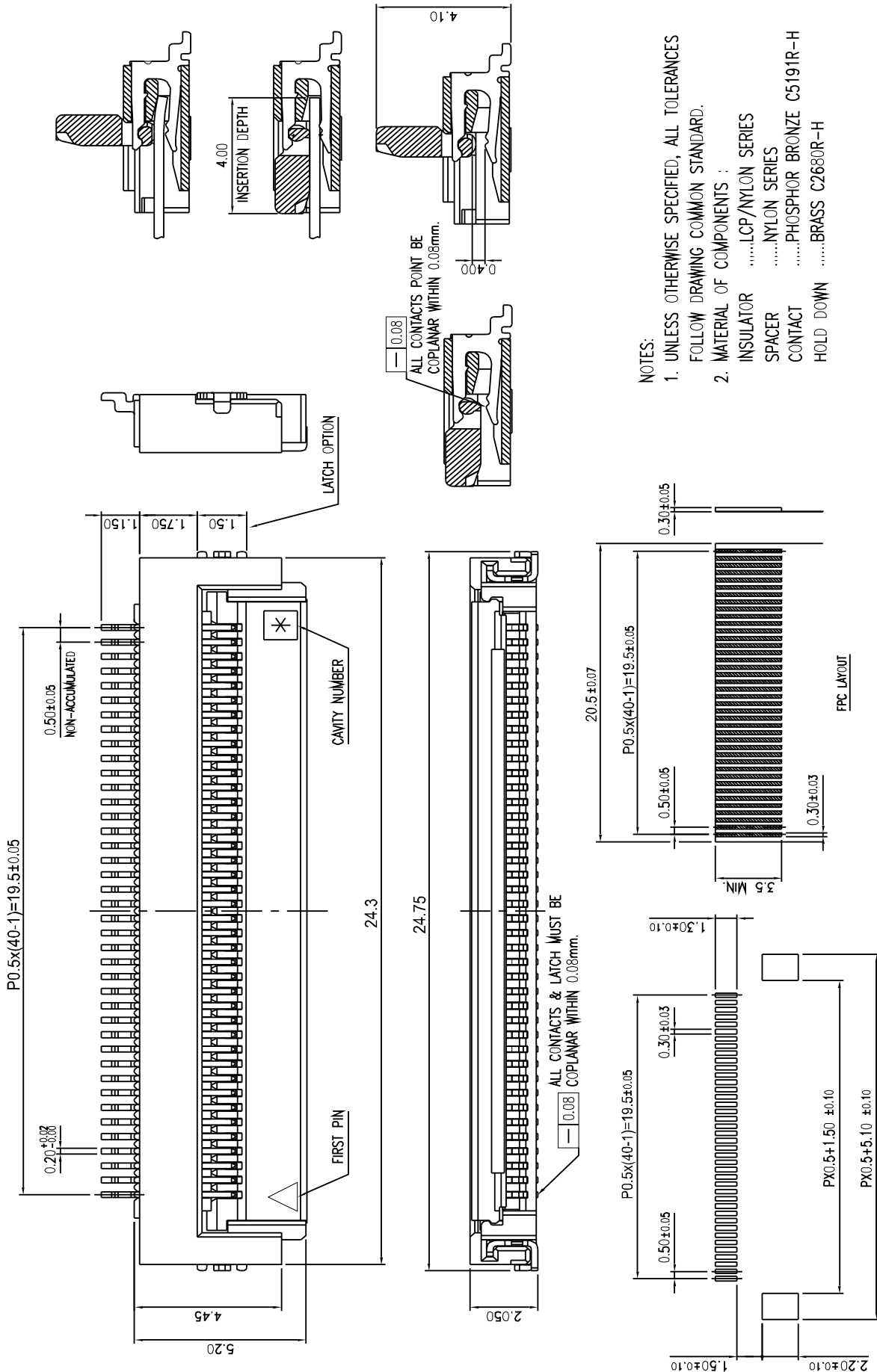

NOTES:

1. UNLESS OTHERWISE SPECIFIED, ALL TOLERANCES FOLLOW DRAWING COMMON STANDARD.
2. MATERIAL OF COMPONENTS :
 - INSULATORLCP/NYLON SERIES
 - SPACERNYLON SERIES
 - CONTACTPHOSPHOR BRONZE C5191R-H
 - HOLD DOWNBRASS C2680R-H

RECOMMENDED P.C. BOARD PATTERN LAYOUT
 RECOMMENDED METAL MASK THICKNESS: T=0.15

8. OPTICAL CHARACTERISTICS

VCC=3.3V

Ta=25°C

ITEM	SYMBOL	CONDITION	MIN.	TYP.	MAX.	UNIT	Remarks	
Constrast Ratio	CR	Point-5	300	400	--	--	*1)*2)*3)	
Luminance*)	Lw		200	250	--	cd/m ²	*2)*3)	
Luminance Uniformity	ΔL		70	80		%	*2)*3)	
Response Time (White - Black)	Tr		--	12		ms	*3)*4)	
	Tf			18		ms		
Viewing Angle	Horizontal	ϕ	CR ≥ 10 Point-5	120	140	--	°	*2)*3)
	Vertical	θ		80	100	--	°	*2)*3)
Color Coordinate	White	Wx Wy	$\theta = \phi = 0'$ Point-5	0.283 0.299	0.313 0.329	0.343 0.359	--	*2)*3)
	Red	Rx Ry		0.550 0.284	0.580 0.314	0.610 0.344		
	Green	Gx Gy		0.271 0.534	0.301 0.564	0.331 0.594		
	Blue	Bx By		0.118 0.093	0.148 0.123	0.178 0.153		

[NOTE]

- Brightness conditions: $I_L=180\text{mA}$

(1) Definition of contrast ratio:

Contrast Ratio (CR)=(White) Luminance of ON/ (Black) Luminance of OFF

(2) Definition of luminance:

Measure white luminance on the point 5 as figure8-1

Definition of Luminance Uniformity:

Measure white luminance on the point 1~5 as figure8-1

$$\Delta L=[L(\text{Min})/L(\text{Max})]*100$$

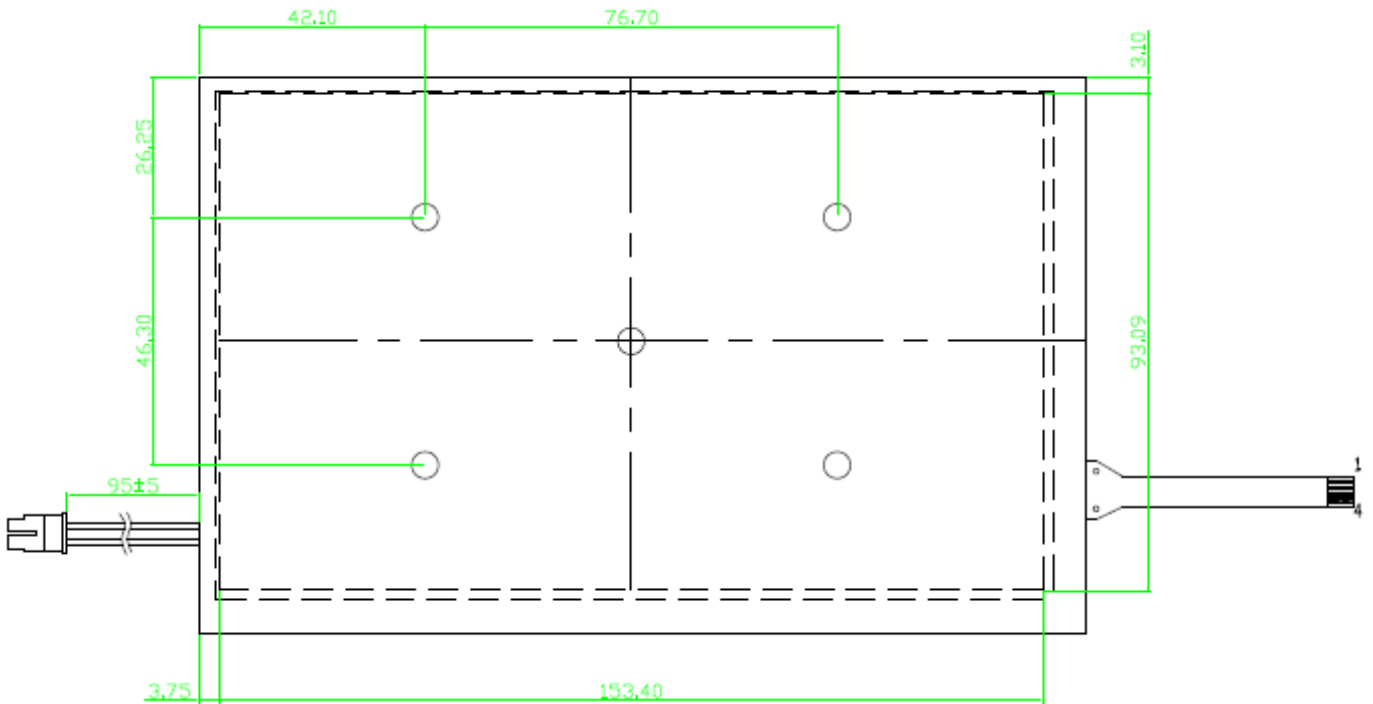

(3) Definition of Viewing Angle (θ , ϕ), refer to Fig8-2 as below:

These items are measured by EZ-CONTRAST(ELDIM) in the dark room. (no ambient light)

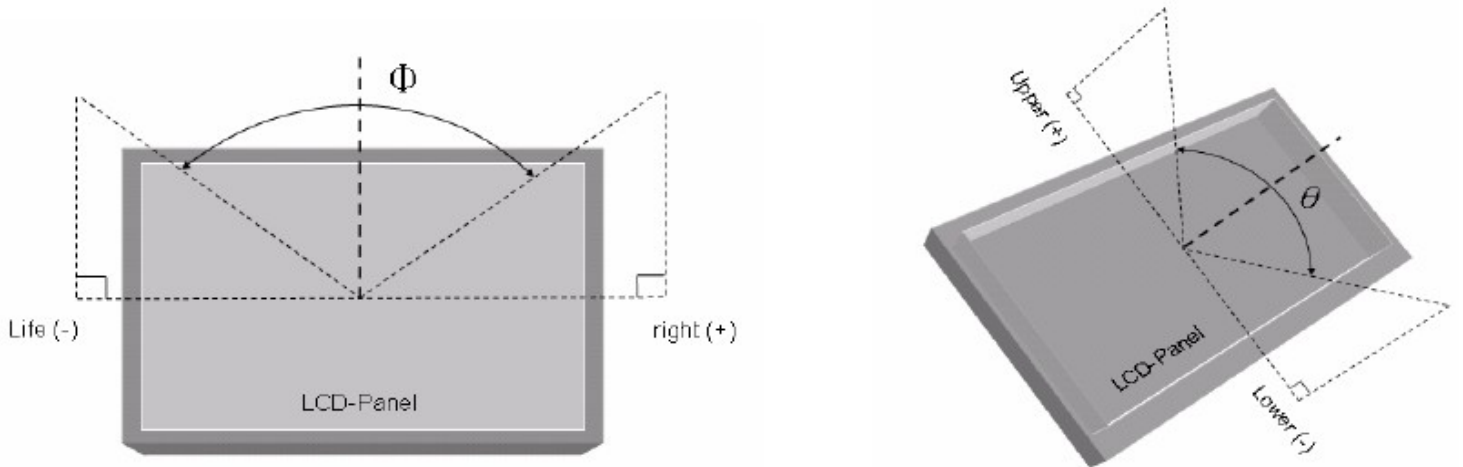

Fig8-2 Definition of Viewing Angle

(4) Definition of Response Time (White-Black)

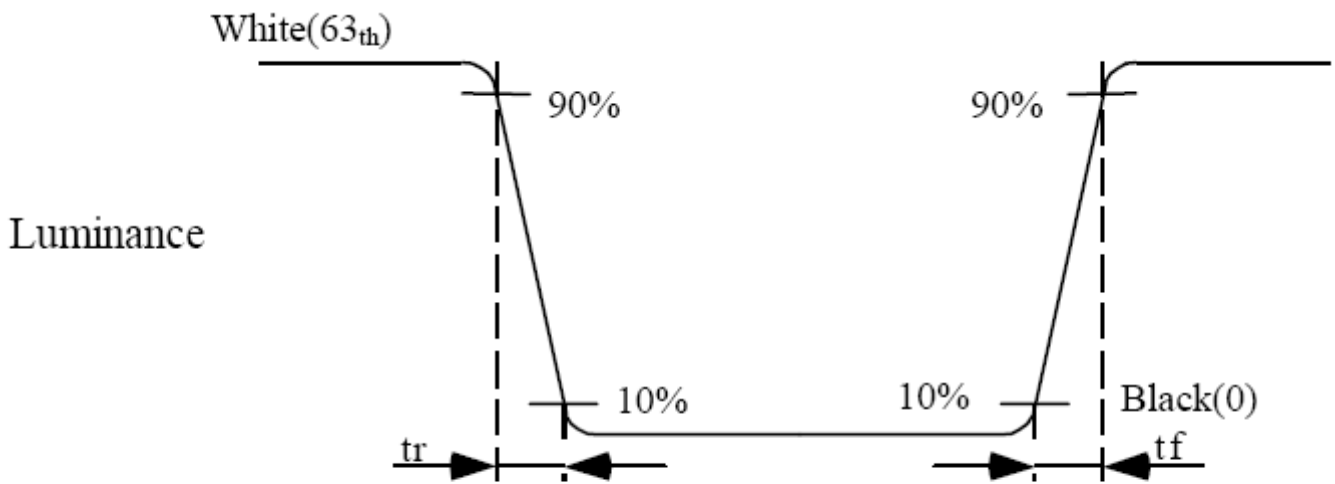

Fig8-3 Definition of Response Time(White-Black)

9. REILIBILITY TEST

9.1 Temperature and humidity

Reliability Test	
TEST ITEMS	CONDITIONS
HIGH TEMPERATURE OPERATION	60° C ; 240Hrs
HIGH TEMPERATURE AND HIGH HUMIDITY OPERATION	55° C ; 90% RH ; 240Hrs
HIGH TEMPERATURE AND HIGH HUMIDITY STORAGE	60° C ; 90% RH Max. ; 48Hrs
HIGH TEMPERATURE STORAGE	70° C ; 240Hrs
LOW TEMPERATURE OPERATION	0° C ; 240Hrs, Backlight unit always turn on
LOW TEMPERATURE STORAGE	-30° C ; 240Hrs
THERMAL SHOCK (No operation)	-20° C (0.5Hr)~60° C (0.5Hr) 200 CYCLE

9.2 Shock and Vibration

TEST ITEMS	CONDITIONS
Shock (Non-operation)	<ul style="list-style-type: none"> ● Shock level:980m/s2(equel to 100G) ● Waveform:half sinusoidal wave,6ms. ● Number of shocks:one shock input in each direction of three mutually perpendicular axes for a total of three shock inputs.
Vibration (Non-operation)	<ul style="list-style-type: none"> ● Frequency range:8~33.3Hz ● Stoke:1.3mm ● Vibration:sinusodial wave,perpendicularaxis(both x,y,z axis:2Hrs). ● Sweep:2.9G,33.3Hz-400Hz ● Cycle:15min

9.3 Judgment standard

The judgment of the above test should be made as follow:

Pass: Normal display image with no obvious non-uniformity and no line defect. Partial trasformation of the module parts should be ignored.

Fail: No display image, obvious non-uniformity, or line defect.

10. HANDLING PRECAUTIONS FOR TFT-LCD MODULE

Please pay attention to the followings in handling TFT-LCD products.

(A) ASSEMBLY PRECAUTION

- (1) Please use the mounting hole on the module side in installing and do not beading or wrenching LCD in assembling. And please do not drop, bend or twist LCD module in handling.
- (2) Please design display housing in accordance with the following guide lines.
 - (2.1) Housing case must be destined carefully so as not to put stresses on LCD all sides and not to wrench module. The stresses may cause non-uniformity even if there is no non-uniformity statically.
 - (2.2) Keep sufficient clearance between LCD module back surface and housing when the LCD module is mounted. Approximately 1.0mm of the clearance in the design is recommended taking into account the tolerance of LCD module thickness and mounting structure height on the housing.
 - (2.3) When some parts, such as, FPC cable and ferrite plate, are installed underneath the LCD module, still sufficient clearance is required, such as 0.5mm. This clearance is, especially, to be reconsidered when the additional parts are implemented for EMI countermeasure.
 - (2.4) Design the inverter location and connector position carefully so as not to give stress to lamp cable, or not to interface the LCD module by the lamp cable.
 - (2.5) Keep sufficient clearance between LCD module and the others parts, such as inverter and speaker so as not to interface the LCD module. Approximately 1.0mm of the clearance in the design is recommended.
- (3) Please do not push or scratch LCD panel surface with any-thing hard. And do not soil LCD panel surface by touching with bare hands. (Polarizer film, surface of LCD panel is easy to be flawed.)
- (4) Please do not press any parts on the rear side such as source TCP, gate TCP, control circuit board and FPCs during handling LCD module. If pressing rear part is unavoidable, handle the LCD module with care not to damage them.
- (5) Please wipe out LCD panel surface with absorbent cotton or soft cloth in case of it being soiled.
- (6) Please wipe out drops of adhesives like saliva and water on LCD panel surface immediately. They might damage to cause panel surface variation and color change.
- (7) Please do not take a LCD module to pieces and reconstruct it. Resolving and reconstructing modules may cause them not to work well.
- (8) Please do not touch metal frames with bare hands and soiled gloves. A color change of the metal frames can happen during a long preservation of soiled LCD modules.
- (9) Please pay attention to handling lead wire of backlight so that it is not tugged in connecting wit inverter.

(B) OPERATING PRECAUTIONS

- (1) Please be sure to turn off the power supply before connecting and disconnecting signal input cable.
- (2) Please do not change variable resistance settings in LCD module. They are adjusted to the most suitable value. If they are changed, it might happen LCD does not satisfy the characteristics specification.
- (3) Please consider that LCD backlight takes longer time to become stable of radiation characteristics in low temperature than in room temperature.
- (4) A condensation might happen on the surface and inside of LCD module in case of sudden change of ambient temperature.
- (5) Please pay attention to displaying the same pattern for very long time. Image might stick on LCD. If then, time going on can make LCD work well.
- (6) Please obey the same caution descriptions as ones that need to pay attention to ordinary electronic parts.

(C) PRECAUTIONS WITH ELECTROSTATICS

- (1) This LCD module use CMOS-IC on circuit board and TFT-LCD panel, and so it is easy to be affected by electrostatics. Please be careful with electrostatics by the way of your body connecting to the ground and so on.
- (2) Please remove protection film very slowly on the surface of LCD module to prevent from electrostatics occurrence.

(D) STORAGE PRECAUTIONS

- (1) When your store LCDs for a long time, it is recommended to keep the temperature between 0°C -40°C without the exposure of sunlight and to keep the humidity less than 90% RH.
- (2) Please do not leave the LCDs in the environment of high humidity and high temperature such as 60°C 90%RH.
- (3) Please do not leave the LCDs in the environment of low temperature, below -20°C

(E) SAFETY PRECAUTIONS

- (1) When you waste LCDs, it is recommended to crush damaged or unnecessary LCDs into pieces and wash them off with solvents such as acetone and ethanol, which should later be burned.
- (2) If any liquid leaks out of a damaged-glass cell and comes in contact with the hands, wash off thoroughly with soap and water

(F) OTHERS

- (1) A strong incident light into LCD panel might cause display characteristics' changing inferior because of polarizer film, color filter, and other materials becoming inferior. Please do not expose LCD module direct sunlight and strong UV rays.
- (2) Please pay attention to a panel side of LCD module not to contact with other materials in preserving it alone.
- (3) For the. packaging box, please pay attention to the followings:
 - (3.1) Packaging box and inner case for LCD are designed to protect the LCDs from the damage or scratching during transportation. Please do not open except picking LCDs up from the box.
 - (3.2) Please do not pile them up more than 5 boxes. (They are not designed so.) And please do not turn over.
 - (3.3) Please handle packaging box with care not to give them sudden shock and vibrations. And also please do not throw them up.
 - (3.4) Packing box and inner case for LCDs are made of cardboard. So please pay attention not to get them wet. (Such like keeping them in high humidity or wet place can occur getting them wet.)