

SPECIFICATIONS

CUSTOMER : _____

SAMPLE CODE : GFG128064L-YPAE-01

DRAWING NO. : _____

DATE : 2010.05.25

CERTIFICATION : ROHS

Customer Sign	Sales Sign	Approved By	Prepared By

Revision Record

Data(y/m/d)	Ver.	Description	Note	page
2010.05.25	00	New		

CONTENTS

1. SCOPE	-----	4
2. PRODUCT SPECIFICATIONS	-----	4
2.1 General	-----	4
2.2 Mechanical Characteristics	-----	4
2.3 Absolute Maximum Ratings	-----	5
2.4 Electrical Characteristics	-----	5
2.5 Optical Characteristics Absolute maximum ratings	-----	5
2.6 Optical Characteristics	-----	6
2.7 LED Back-light Characteristics	-----	7
3. RELIABILITY	-----	8
4. OPERATING INSTRUCTIONS	-----	9

4.1	Input signal Function	-----	9
4.2	Voltage Generator Circuit	-----	10
4.3	Timing Diagram	-----	11
5.	COMMAND TABLE	-----	12
6.	NOTES	-----	13
7.	OPERATION PRECAUTIONS	-----	13
8.	LCM DIMENSIONS	-----	14

1. SCOPE

This specification covers the engineering requirements for the GFG128064L-YPAE-01 liquid crystal module.

2. PRODUCT SPECIFICATIONS

2.1 General

- 128 \times 64 dot matrix LCD
- STN (Yellow-Green) , Positive mode LCD panel
- Transflective , Wide temperature type
- 6 o'clock
- Back light: Edge LED (Yellow-Green)
- Multiplexing driving : 1/65duty, 1/9bias
- Conteroller IC ST7565
- Special code 01:FPC stiffener is 35mm

2.2 Mechanical Characteristics

Item	Characteristic
Dot configuration	128 \diamond 64
Dot dimensions(mm)	0.48 \diamond 0.48
Dot spacing (mm)	0.52 \diamond 0.52
Module dimensions (Horizontal \diamond Vertical \diamond Thickness, mm)	87 \diamond 53 \diamond 5.5 max.
Viewing area (Horizontal \diamond Vertical, mm)	70.7 \diamond 38.8
Active area (Horizontal \diamond Vertical, mm)	66.52 \diamond 33.24

2.3 Absolute

Maximum Ratings (Without LED back-light)

Characteristic	Symbol	Unit	Value
Operating Voltage (logic)	V_{DD}	V	-0.3 to +5.0
Input Voltage	V_{IN}	V	-0.3 to $V_{DD}+0.3$

Note 1: Referenced to $V_{SS}=0V$

2.4 Electrical Characteristics (Without LED back-light)

Characteristic	Symbol	Condition	Min.	Typ.	Max.	Unit
Operating Voltage(logic)	$V_{DD}-V_{SS}$	--	3.0	3.3	3.6	V
Input Voltage	V_{IH}	--	$0.8V_{DD}$	--	V_{DD}	V
	V_{IL}	--	V_{SS}	--	$0.2V_{DD}$	
Output Voltage	V_{OH}	$I_{OH}=-0.1mA$	$0.8V_{DD}$	--	V_{DD}	V
	V_{HL}	$I_{OL}=0.1mA$	V_{SS}	--	$0.2V_{DD}$	
Current Consumption	I_{DD}	$V_{IN}=V_{DD}$	--	0.05	1	mA

2.5 Optical Characteristics Absolute maximum ratings

Item	Symbol	Rating	Unit
Operating temperature range	Top	-20~70	\oplus C
Storage temperature range	Tst	-30~80	\oplus C

2.6 Optical Characteristics

1/65 duty, 1/9bias, $V_{op}=10.3V$, $T_a=25^\circ C$

Item	Symbol	Conditions	Min.	Typ.	Max	Reference
Driving voltage	$V_{op}=V_{DD}-V_{O}$		-	10.3	-	
Viewing angle	-	$C \geq 2.0, \theta = 0^\circ$	30	-		Notes 1 & 2
Contrast	C	$\theta = 5^\circ, \Phi = 0^\circ$	3.0	--	-	Note 3
Response time(rise)	t_{on}	$\theta = 5^\circ, \Phi = 0^\circ$	-		198ms	Note 4
Response time(fall)	t_{off}	$\theta = 5^\circ, \Phi = 0^\circ$	-	-	176ms	Note 4

Note 1: Definition of angles θ and Φ

Note 2: Definition of viewing angles θ_1 and θ_2

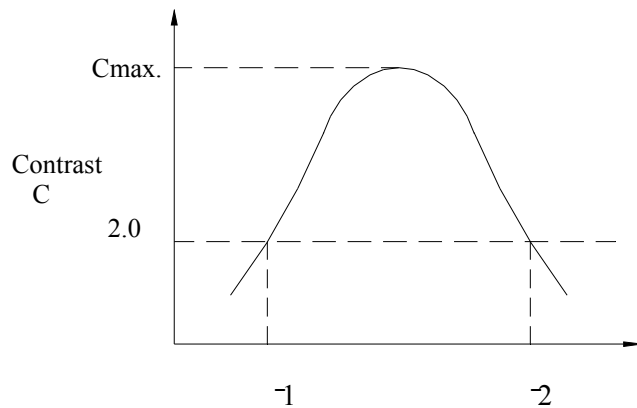
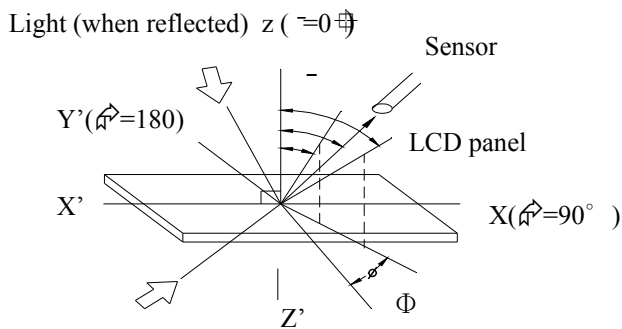

Light (when transmitted) $\theta = 0^\circ$
 $(\theta = 90^\circ)$

viewing angle θ (Φ fixed)

Note : Optimum viewing angle with the naked eye and viewing angle θ at C_{max} . Above are not always the same

Note 3: Definition of contrast C

Note 4: Definition of response time

$$C = \frac{\text{Brightness (reflection) of unselected dot (B2)}}{\text{Brightness (reflection) of selected dot (B1)}}$$

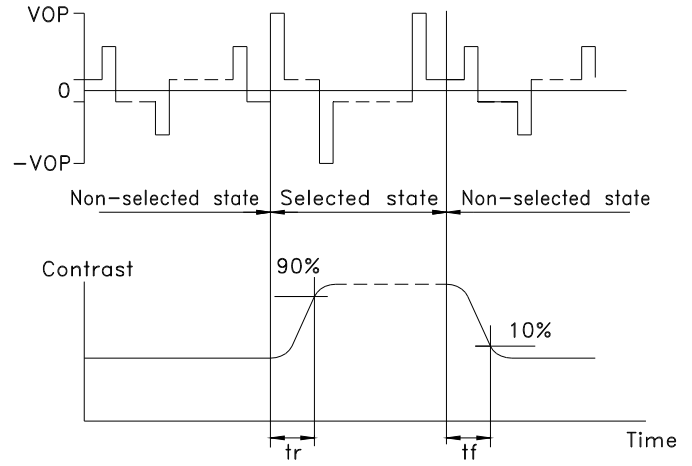
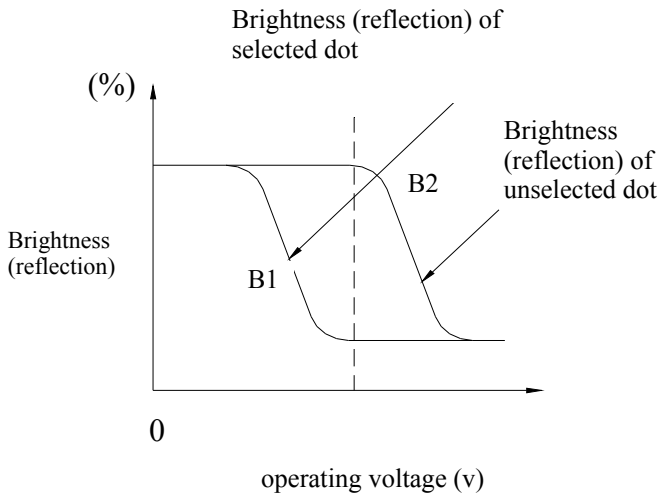

Note: Measured with a transmissive LCD panel which is displayed 1 cm²

V_{OPR} : Operating voltage f_{FRM} : Frame frequency
 t_{ON} : Response time (rise) t_{OFF} : Response time (fall)

2.7 LED Back-light Characteristics

2.7.1 Electrical / optical specifications

$T_a = 25^{\circ}C$

Item	Symbol	Condition	Min.	Typ.	Max.	Unit
Forward voltage	V_f	$I_f=70mA$, Yellow Green	3.8	4.2	4.4	V
*Luminous Intensity	I_v	$I_f=70mA$, Yellow Green	25	35	--	Cd/m ²
Peak Emission Wavelength	λ_p	$I_f=70mA$, Yellow Green	570	573	576	nm
Spectrum Radiation Bandwidth	λ_{band}	$I_f=70mA$, Yellow Green	--	30	--	nm
Reverse Current	I_R	$V_R=5V$, Yellow Green	--	--	0.7	mA

Note: * Measured at the bare LED back-light unit.

2.7.2 LED Maximum Operating Range

Item	Symbol	Yellow-Green	Unit
Power Dissipation	P_{AD}	308	mW
Forward Current	I_F	70	mA
Reverse Voltage	V_R	5	V

3. RELIABILITY

3.1 Reliability

Test item	Test condition	Evaluation and assessment
Operation at high temperature and humidity	40 °C \pm 2 °C 90%RH for 500hours	No abnormalities in functions* and appearance**
Operation at high temperature	60 °C \pm 2 °C for 500 hours	No abnormalities in functions* and appearance**
Heat shock	-20 ϕ ~ +60 °C Left for 1 hour at each temperature, transition time 5 min, repeated 10times	No abnormalities in functions* and appearance**
Low temperature	-20 ϕ 2 °C for 500 hours	No abnormalities in functions* and appearance**
Vibration	Sweep for 1 min at 10 Hz, 55Hz, 10Hz, amplitude 1.5mm 2 hrs each in the X,Y and Z directions	No abnormalities in functions* and appearance**
Drop shock	Dropped onto a board from a height of 10cm	No abnormalities in functions* and appearance**

* Dissipation current, contrast and display functions

** Polarizing filter deterioration, other appearance defects

3.2 Liquid crystal panel service life

100,000 hours minimum at 25 °C ±10 °C

3.3 definition of panel service life

- Contrast becomes 30% of initial value
- Current consumption becomes three times higher than initial value
- Remarkable alignment deterioration occurs in LCD cell layer
- Unusual operation occurs in display functions

4. OPERATING INSTRUCTIONS

4.1 Input signal Function

Pin No	Symbol	I/O	Function
1	/CS1	I	This is the chip select signal. When CS1 = "L"
2	/RES	I	When RES is set to "L," the settings are initialized. The reset operation is performed by the RES signal level.
3	A0	I	This is connect to the least significant bit of the normal MPU address bus, and it determines whether the data bits are data or a command. A0 = "H": Indicates that D0 to D7 are display data. A0 = "L": Indicates that D0 to D7 are control data.
4	WR	I	• When connected to an 8080 MPU, this is active LOW. (R/W) This terminal connects to the 8080 MPU WR signal. The signals on the data bus are latched at the rising edge of the WR signal.
5	RD	I	• When connected to an 8080 MPU, this is active LOW. This pin is connected to the RD signal of the 8080 MPU, and the
6~13	D0 to D7	I/O	This is an 8-bit bi-directional data bus that connects to an 8-bit standard MPU data bus.
14	VDD	PS	Shared with the MPU power supply terminal Vcc.
15	VSS	PS	This is a 0V terminal connected to the system GND.
16	VOUT	O	DC/DC voltage converter. Connect a capacitor between this terminal and VSS.
17	CAP3P	O	DC/DC voltage converter. Connect a capacitor between this terminal and the CAP1+ terminal.
18	CAP1N	O	DC/DC voltage converter. Connect a capacitor between this terminal and the CAP1- terminal.
19	CAP1P	O	DC/DC voltage converter. Connect a capacitor between this terminal and the CAP1+ terminal.
20	CAP2P	O	DC/DC voltage converter. Connect a capacitor between this terminal and the CAP2+ terminal.

21	CAP2N	O	DC/DC voltage converter. Connect a capacitor between this terminal and the CAP2- terminal.
22~26	V1,V2, V3,V4, V0		This is a multi-level power supply for the liquid crystal drive. The voltage Supply applied is determined by the liquid crystal cell, and is changed through the use of a resistive voltage divided or through changing the impedance using an op.amp. Voltage levels are determined based on VDD, and must maintain the relative magnitudes shown below. $VDD (= V0) \geq V1 \geq V2 \geq V3 \geq V4 \geq V0$

4.2 Voltage Generator Circuit

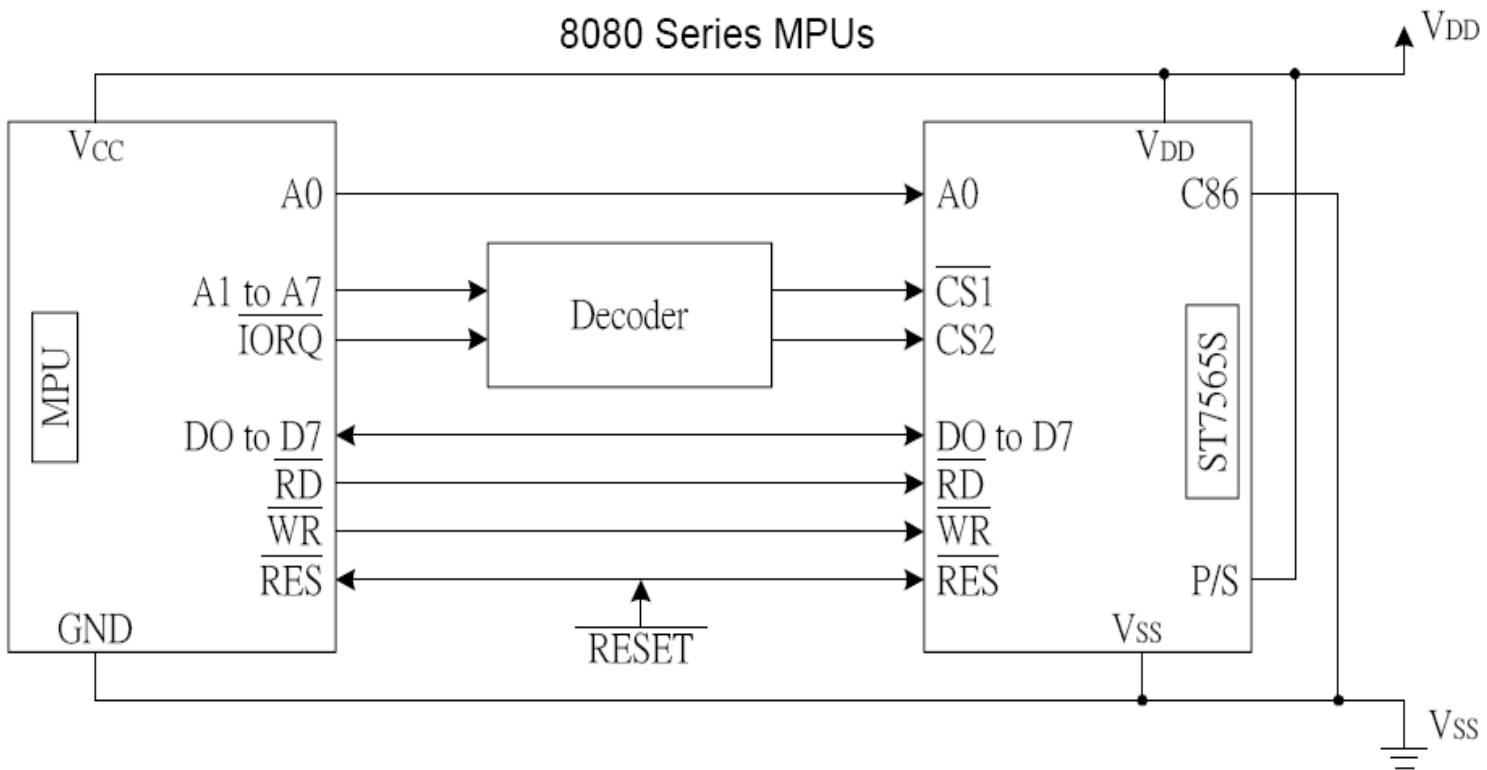

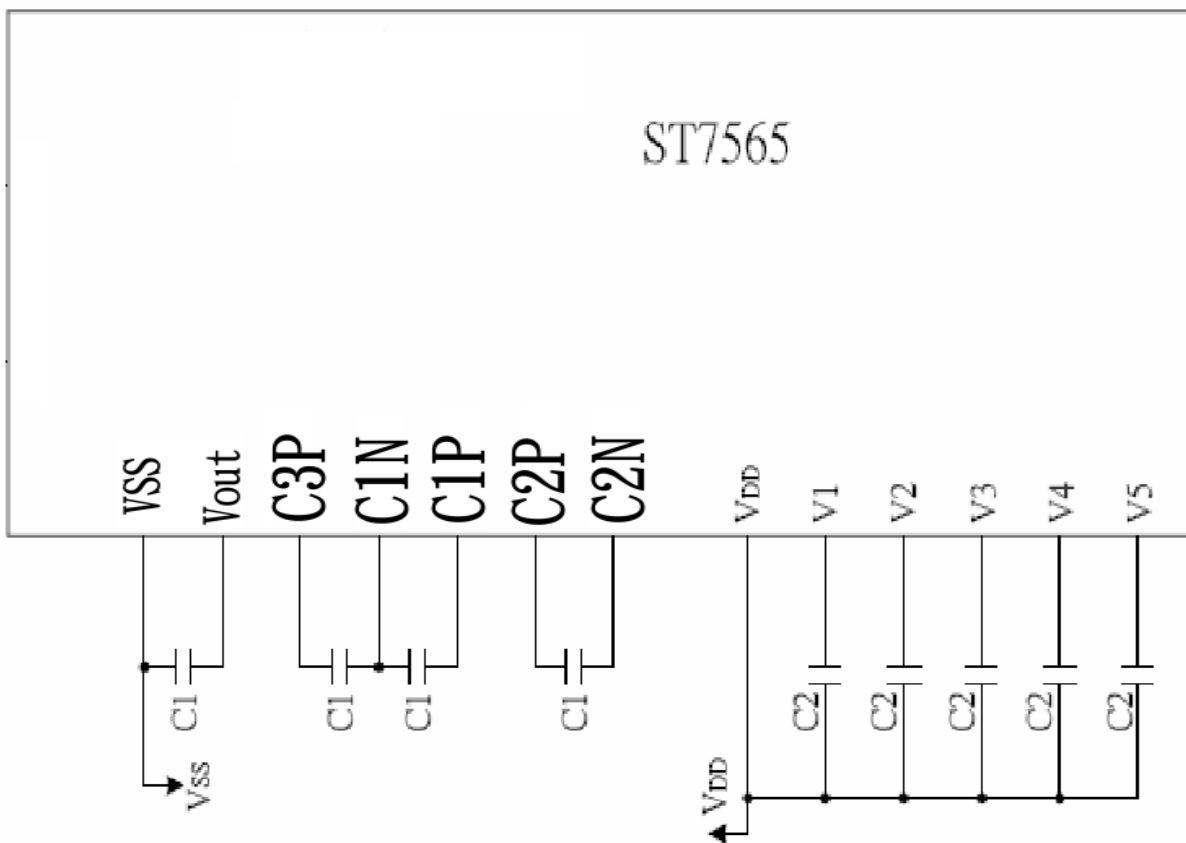

Item	Set value	units
c1	1.0 to 4.7	uF
c2	0.1 to 4.7	uF

4.3 Timing Diagram

System Bus Read/Write Characteristics 1 (For the 8080 Series MPU)

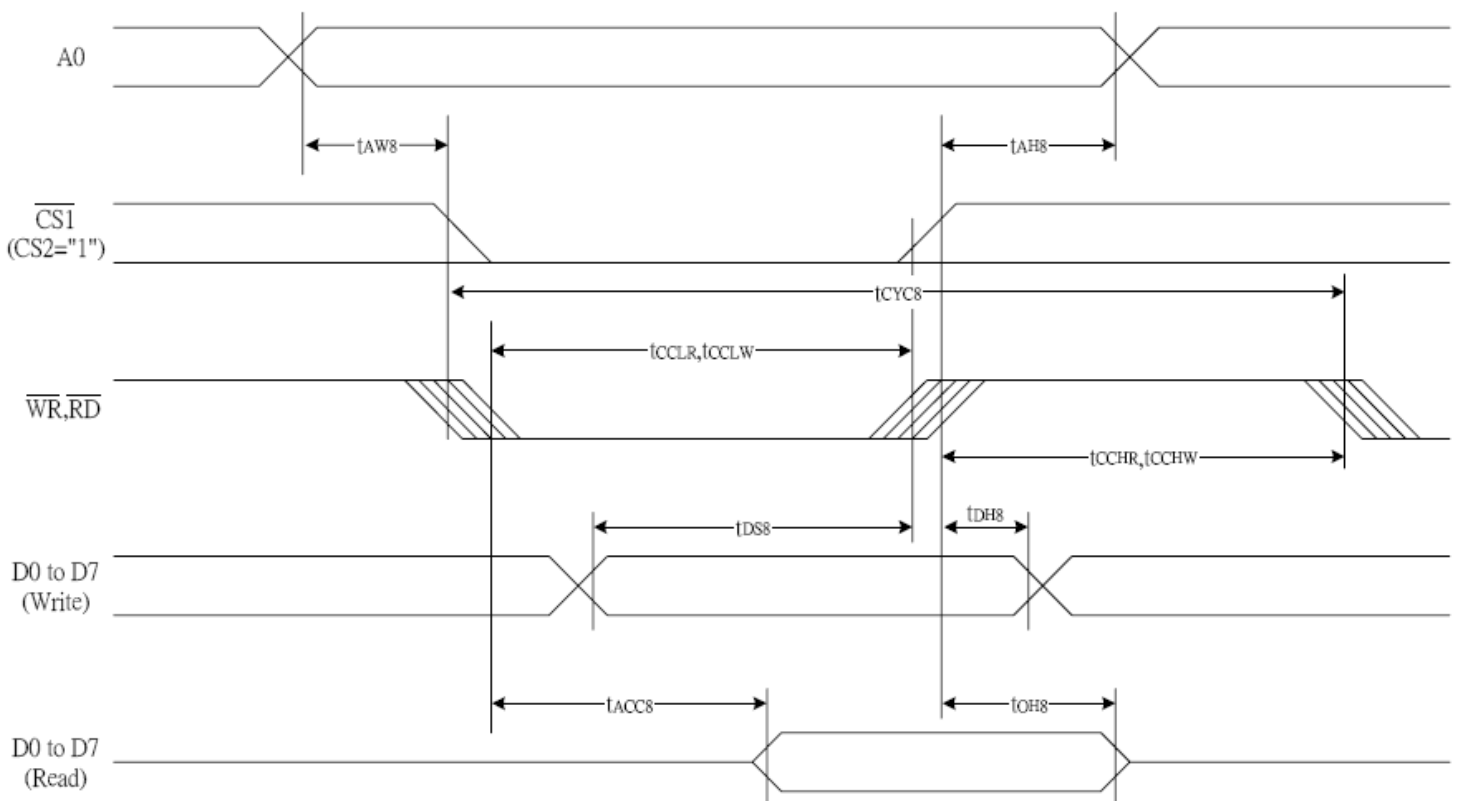

Item	Signal	Symbol	Condition	Rating		Units
				Min	Max.	
Address hold time	A0	t_{AH8}	--	0	--	ns
Address setup time		t_{AW8}		0	--	ns
System cycle time	A0	t_{CYC8}	--	240		
Control L pulse width (WR)	WR	t_{CCLW}	--	80	--	ns
Control L pulse width (RD)	RD	t_{CCLR}		140	--	ns
Control H pulse width (WR)	WR	t_{CCHW}		80	--	ns
Control H pulse width (RD)	RD	t_{CCHR}		80	--	ns
RD access time	D0 to D7	t_{DS8}	--	40	--	ns
Output disable time		t_{DH8}		10	--	ns
		t_{ACC8}	$C_L=100pF$	--	70	ns
		t_{OH8}		5	50	ns

5. COMMAND TABLE

Command	Command Code										Function		
	A0	/RD	/WR	D7	D6	D5	D4	D3	D2	D1		D0	
(1) Display ON/OFF	0	1	0	1	0	1	0	1	1	1	0	1	LCD display ON/OFF 0: OFF, 1: ON
(2) Display start line set	0	1	0	0	1	Display start address						Sets the display RAM display start line address	
(3) Page address set	0	1	0	1	0	1	1	Page address				Sets the display RAM page address	
(4) Column address set upper bit	0	1	0	0	0	0	1	Most significant column address				Sets the most significant 4 bits of the display RAM column address.	
Column address set lower bit	0	1	0	0	0	0	0	Least significant column address				Sets the least significant 4 bits of the display RAM column address.	
(5) Status read	0	0	1	Status				0	0	0	0	0	Reads the status data
(6) Display data write	1	1	0	Write data							Writes to the display RAM		
(7) Display data read	1	0	1	Read data							Reads from the display RAM		
(8) ADC select	0	1	0	1	0	1	0	0	0	0	0	1	Sets the display RAM address SEG output correspondence 0: normal, 1: reverse
(9) Display normal/reverse	0	1	0	1	0	1	0	0	1	1	0	1	Sets the LCD display normal/reverse 0: normal, 1: reverse
(10) Display all points ON/OFF	0	1	0	1	0	1	0	0	1	0	0	1	Display all points 0: normal display 1: all points ON
(11) LCD bias set	0	1	0	1	0	1	0	0	0	1	0	1	Sets the LCD drive voltage bias ratio 0: 1/9 bias, 1: 1/7 bias (ST7565P)
(12) Read/modify/write	0	1	0	1	1	1	0	0	0	0	0	0	Column address increment At write: +1 At read: 0
(13) End	0	1	0	1	1	1	0	1	1	1	0	0	Clear read/modify/write
(14) Reset	0	1	0	1	1	1	0	0	0	1	0	0	Internal reset
(15) Common output mode select	0	1	0	1	1	0	0	0	1	*	*	*	Select COM output scan direction 0: normal direction 1: reverse direction
(16) Power control set	0	1	0	0	0	1	0	1	Operating mode		0		Select internal power supply operating mode
(17) V ₀ voltage regulator internal resistor ratio set	0	1	0	0	0	1	0	0	Resistor ratio		0		Select internal resistor ratio(R _b /R _a) mode
(18) Electronic volume mode set	0	1	0	1	0	0	0	0	0	0	0	1	Set the V ₀ output voltage electronic volume register
Electronic volume register set				0	0	Electronic volume value							
(19) Static indicator ON/OFF	0	1	0	1	0	1	0	1	1	0	0	1	0: OFF, 1: ON
Static indicator register set				0	0	0	0	0	0	0	0	0	0
(20) Booster ratio set	0	1	0	1	1	1	1	1	0	0	0	0	select booster ratio 00: 2x,3x,4x 01: 5x 11: 6x
(21) Power saver													Display OFF and display all points ON compound command
(22) NOP	0	1	0	1	1	1	0	0	0	0	1	1	Command for non-operation
(23) Test	0	1	0	1	1	1	1	*	*	*	*	*	Command for IC test. Do not use this command

6. NOTES

Safety

- If the LCD panel breaks, be careful not to get the liquid crystal in your mouth. If the liquid crystal touches your skin or clothes, wash it off immediately using soap and plenty of water.

Handling

- Avoid static electricity as this can damage the CMOS LSI.
- The LCD panel is plate glass; do not hit or crush it.
- Do not remove the panel or frame from the module.
- The polarizing plate of the display is very fragile; handle it very carefully

Mounting and Design

- Mount the module by using the specified mounting part and holes.
- To protect the module from external pressure, leave a small gap by placing transparent plates (e.g. acrylic or glass) on the display surface, frame, and polarizing plate
- Design the system so that no input signal is given unless the power-supply voltage is applied.
- Keep the module dry. Avoid condensation, otherwise the transparent electrodes may break.

Storage

- Store the module in a dark place where the temperature is $25^{\circ}\text{C} \pm 10^{\circ}\text{C}$ and the humidity below 65% RH.
- Do not store the module near organic solvents or corrosive gases.
- Do not crush, shake, or jolt the module (including accessories).

Cleaning

- Do not wipe the polarizing plate with a dry cloth, as it may scratch the surface.
- Wipe the module gently with soft cloth soaked with a petroleum benzine.
- Do not use ketonic solvents (ketone and acetone) or aromatic solvents (toluene and xylene), as they may damage the polarizing plate.

7. OPERATION PRECAUTIONS

Any changes that need to be made in this specification or any problems arising from it will be dealt with quickly by discussion between both companies.

8. LCM Dimension

ROHS

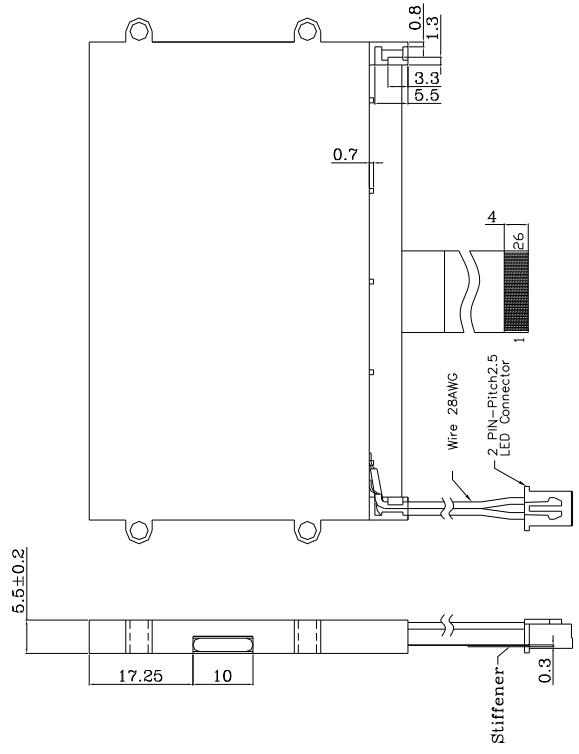
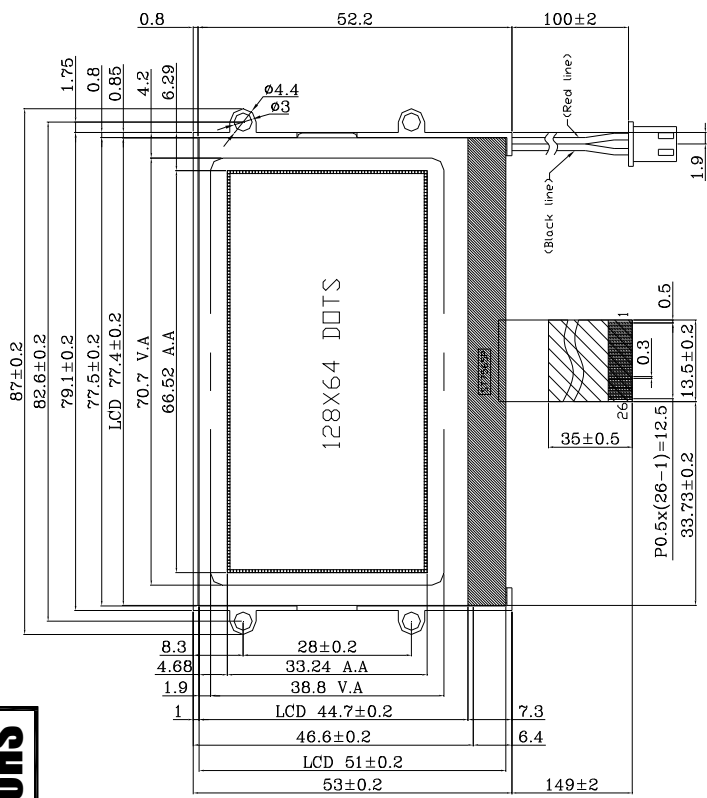

No.	Symbol
1	CSI
2	RESET
3	A0
4	WR
5	RD
6	DB0
7	DB1
8	DB2
9	DB3
10	DB4
11	DB5
12	DB6
13	DB7
14	VDD
15	VSS
16	VOUT
17	C3P
18	CIN
19	C1P
20	C2P
21	C2N
22	V4
23	V3
24	V2
25	V1
26	V0

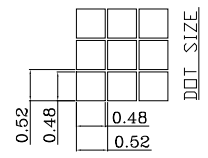

- NOTES:
1. DRIVE METHOD: 1/64DUTY, 1/9BIAS, VOP10.3V.
 2. VIEWING ANGLE: 6 O'CLOCK.
 3. DISPLAY TYPE:STN(Y/G),TRANSFLECTIVE/POSITIVE.
 4. OPERATING TEMP: -20 TO 70°C.
 5. STORAGE TEMP: -30 TO 80°C.
 6. CONNECTION: COG+FPC
 7. CONTROLLER IC:ST7565P.
 8. BACKLIGHT-YELLOW GREEN(4.2V,70mA).
 9. NOT DIMENSION TOLERANCES IS ±0.2.

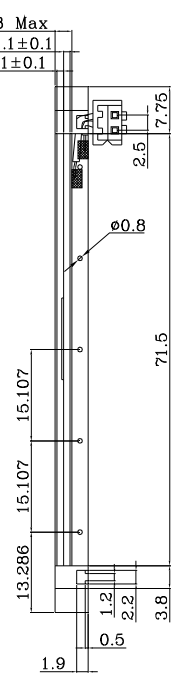

修改内容

版本

日期